

Mitsubishi Electric Research Laboratories (MERL)

Annual Report

April 2018 through March 2019

TR2019-000

(Published June 2019)

Welcome to Mitsubishi Electric Research Laboratories (MERL), the North American corporate R&D arm of Mitsubishi Electric Corporation. In this report, you will find descriptions of MERL and our projects.

This work may not be copied or reproduced in whole or in part for any commercial purpose. Permission to copy in whole or in part without payment of fee is granted for nonprofit educational and research purposes provided that all such whole or partial copies include the following: a notice that such copying is by permission of Mitsubishi Electric Research Laboratories; an acknowledgment of the authors and individual contributions to the work; and all applicable portions of the copyright notice. Copying, reproduction, or republishing for another purpose shall require a license with payment of fee to Mitsubishi Electric Research Laboratories. All rights reserved.

Copyright © Mitsubishi Electric Research Laboratories, 2019
201 Broadway, Cambridge, Massachusetts 02139
617.621.7500

Production:

Marissa Deegan, Richard C. Waters

Table of Contents

Mitsubishi Electric Research Laboratories	1
Awards and Commendations	7
Technical Staff	9
Publications	25
Research	41
Computer Vision	43
Data Analytics	51
Speech & Audio	59
Signal Processing	65
Control & Dynamical Systems	73
Multi-Physical Systems & Devices	81

Mitsubishi Electric Research Laboratories

Mitsubishi Electric Research Laboratories (MERL) is the US subsidiary of the corporate research and development organization Mitsubishi Electric Corporation. MERL conducts application-motivated basic research and advanced development in: Physical Modelling & Simulation, Signal Processing, Control, Optimization, and Artificial Intelligence. The main body of this report presents our recent research in these areas.

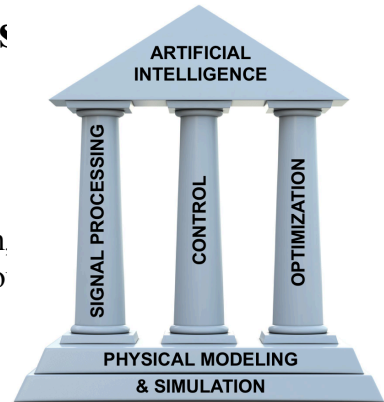

MERL's mission—our assignment from Mitsubishi Electric:

- Generating new technology and intellectual property in areas of importance to Mitsubishi Electric.
- Impacting Mitsubishi Electric's business significantly: using our technical expertise in partnership with organizations in Mitsubishi Electric to produce new and improved products in Mitsubishi Electric's main areas of business.

MERL's vision—our goal for ourselves:

- Being a premiere research laboratory, doing long-term fundamental research that advances the frontiers of technology and makes lasting impacts on the world.
- Being the prime source of technology for Mitsubishi Electric in our areas of expertise.

MERL's values—how we operate:

- Recruiting the highest-quality researchers and developing them into leaders in their fields, encouraging everyone to be a principal investigator and pursue their passions.
- Fostering interdisciplinary teamwork inside MERL with our colleagues at Mitsubishi Electric, and with interns and universities.
- Participating in the world research community, publishing our work while maintaining the confidentiality of business information.
- Combining nimble bottom-up research direction setting with stable long-term support from our large parent organization.
- Enabling researchers to both extend the frontier of science and make real products happen through the large and capable engineering workforce of Mitsubishi Electric.
- Providing excellent benefits and a flexible work environment.

This annual report is a snapshot of MERL's web site. For additional and updated information please visit "www.merl.com".

Richard C. Waters
President, MERL

MERL Organization

MERL is organized as six groups centered on technology areas, which collaborate closely to achieve groundbreaking results. We use a relatively flat organization to enhance the opportunities for collaboration within MERL. The five members of the top management team work closely together, guiding all aspects of MERL's operation.



Richard C. (Dick) Waters *Ph.D., MIT, 1978*
President, CEO & MERL Fellow, ACM Distinguished Scientist

Dick Waters received his Ph.D. in Artificial Intelligence (AI). For 13 years he worked at the MIT AI Lab as a Research Scientist and co-principal investigator of the Programmer's Apprentice project. Dick was a founding member of MERL's Research Lab in 1991. At MERL, his research centered on multi-user interactive environments for work, learning, and play. In 1999, he became CEO of MERL as a whole.



Akira Ishihara *Ph.D., University of Osaka, 2010*
Executive Vice President & CFO

Akira joined Mitsubishi Electric in 1993 and did research on software platforms for computer supported cooperative work, supervisory control and data acquisition systems, and manufacturing execution systems. He has also done research on software engineering technology and is interested in applying it to designing large-scale industrial systems. Before joining MERL in 2018, he was the manager of the Strategic Planning Department in Mitsubishi Electric's Advanced Technology Center.



Jinyun Zhang *Ph.D., University of Ottawa, 1991*
Vice President, Director & MERL Fellow, IEEE Fellow

Before joining MERL in 2001, Jinyun worked for Nortel Networks for 10 years where she held engineering and management positions in the areas of VLSI design and advanced wireless & optical technology development. She joined MERL's management in 2001. In recognition of her contributions to broadband wireless transmission and networking technology she became an IEEE Fellow in 2008.



Anthony Vetro *Ph.D., Polytechnic U. (now part of NYU), 2001*
Vice President & Director, IEEE Fellow

Anthony joined MERL in 1996 and conducted research in the area of multimedia signal processing. He has contributed to the transfer and development of several technologies to digital television, surveillance, automotive, and satellite imaging systems. He has been an active participant in video coding standards and has also served in various leadership roles for conferences, technical committees and editorial boards. He joined MERL's top management in 2014.



Elizabeth Phillips *B.A., University of Massachusetts Amherst, 1988*
Director, Human Resources & Administration

Elizabeth has over 25 years of human resources experience. For 12 years before joining MERL in 2014 she was the principal of a boutique human resources consulting firm in New England, which supported small to mid-size companies with all aspects of their employee related needs. Engagements included: on-site HR leadership, development of talent management programs, management of total rewards programs, facilitation of employee development programs, and HR compliance and administration.

Mitsubishi Electric

One of the world’s largest companies, Mitsubishi Electric Corporation has \$41 billion in annual sales, \$2.6 billion in operating profits (in the year ending in March 2019) and more than 139,000 employees around the world (see www.mitsubishielectric.com).

Mitsubishi Electric is composed of a wide range of operations. The primary business units are listed below.

Mitsubishi Electric Corp.
Information Systems & Network Services IT Systems, Information Security/Encryption Systems, Business Solutions
Public Utility Systems Government Systems, Transportation Systems
Energy & Industrial Systems Electrical Generators, Power Transmission and Distribution Equipment
Building Systems Elevators, Escalators, Building Monitoring/Security/Management Systems
Electronic Systems Satellites, Radar Systems, Antennas, Electronic Toll Collection Systems
Communication Systems Wired & Wireless Communication, Broadcasting Equipment and Systems
Living Environment & Digital Media Equipment Air Conditioners, Home Appliances
Factory Automation Systems Programmable Logic Controllers, Inverters, Servo-motors, Processing Machines
Automotive Equipment Automotive Electrical Equipment, Car Electronics/Multimedia, Car Mechatronics
Semiconductor & Device Optical Devices, High-Frequency & High-Power Semiconductors

Together, these ten business units produce most of Mitsubishi Electric’s revenue. Due to the wide applicability of MERL’s research, MERL works with them all.

It is worthy of note that there are over 30 major independent companies in the world that use the word “Mitsubishi” in their names. These companies include Mitsubishi UFJ Financial Group, Mitsubishi Corporation, Mitsubishi Heavy Industries, Mitsubishi Chemical Holdings and Mitsubishi Motors, all of which are also among the world’s largest companies. They have shared roots in 19th century Japan; however, they have been separated for many years and Mitsubishi Electric has been separate from all of them since its founding in 1921.

Mitsubishi Electric's US Operations

A significant part of Mitsubishi Electric's sales are in North America and many of Mitsubishi Electric's business units have North American subsidiaries. The largest US operations are listed below (see www.mitsubishielectric-usa.com).

Mitsubishi Electric Automotive America, Inc. (Detroit MI & Mason OH) Alternators, Ignition Coils, Automotive Electronics
--

Mitsubishi Electric Power Products, Inc. (Pittsburgh PA & Memphis TN) Power Transmission Products, Rail Transportation Systems
--

Mitsubishi Electric USA, Inc. (Los Angeles CA & other cities) Air Conditioners, Elevators, High Power Semiconductors
--

Mitsubishi Electric Automation, Inc. (Chicago IL) Factory Automation Equipment
--

Mitsubishi Electric Corporate R&D

Mitsubishi Electric has a global R&D network comprising five laboratories. The chart below summarizes the primary activities of these labs. MERL collaborates with all of these labs.

Corporate R&D Headquarters (Tokyo)

Advanced Technology R&D Center (Amagasaki & Nagaokakyo, in greater Osaka) Power Electronics, Electro-mechanical, Ecology, Energy, Materials, Devices, Systems and Imaging Technologies
--

Information Technology R&D Center (Ofuna, in greater Tokyo) Information, Communications, Multimedia, Electro-Optic and Microwave Technologies

Industrial Design Center (Ofuna, in greater Tokyo) Product, Interface and Concept Design
--

Mitsubishi Electric Research Laboratories, Inc. (Cambridge MA) Physical Modeling & Simulation, Signal Processing, Optimization, Control and AI
--

Mitsubishi Electric R&D Centre Europe, B.V. (Rennes, France & Edinburgh, Scotland) Communications, Energy and Environmental Technologies
--

Mitsubishi Electric (China) Co, Ltd. (Shanghai, China) Materials Science
--

Awards and Commendations

The high caliber of MERL's research and researchers is evident in a variety of ways. Two are highlighted below. The first is the members of our staff who are Fellows of technical societies. The second is best paper and other awards received from outside organizations. Listed below are awards for the period of this Annual Report.

Current Technical Society Fellows

- Dr. Keisuke Kojima - Fellow, Optical Society of America
- Dr. Huifang Sun - Fellow, Institute of Electrical and Electronic Engineers
- Dr. Anthony Vetro - Fellow, Institute of Electrical and Electronic Engineers
- Dr. Jin Zhang - Fellow, Institute of Electrical and Electronic Engineers

Awards and Major Events

MERL in conjunction with CR&D colleagues in Japan won an R&D 100 award in November 2018 for a computer vision based, deep learning, river water level, detection system fielded as part of Mitsubishi Electric's MAISART AI technology platform.

The paper Zhong-Qiu Wang, Jonathan Le Roux, and John Hershey, "Multi-Channel Deep Clustering: Discriminative Spectral and Spatial Embeddings for Speaker-Independent Speech Separation" received a Best Student Paper Award at the 2018 IEEE International Conference on Acoustics, Speech and Signal Processing (ICASSP 2018).

It is worthy of note that MERL had a large number of papers in some of the most selective and prestigious conferences related to MERL's areas of research: 9 papers at the IEEE International Conference on Acoustics, Speech & Signal Processing (ICASSP) April 2018 and 16 more papers in ICASSP March 2019, 6 papers at the 6th IFAC Conference on Nonlinear Model Predictive Control (NMPC), 5 papers in the International Modelica Conference, 5 papers in the IEEE Conference on Decision and Control (CDC), and 4 papers at the OSA Optical Fiber Conference (OFC).

Technical Staff

By providing a highly productive, collaborative environment, MERL believes that it is more than the sum of its parts; however, there is no question that its only important parts are its people. The following pages present the capabilities and interests of MERL's technical staff members as of the end of the period of this report. Additional information about their work can be found in the publications list and the project descriptions later in this report.



Heejin Ahn *Ph.D., Massachusetts Institute of Technology, 2018*
Visiting Research Scientist

Prior to joining MERL, Heejin worked on control and optimization at MIT, with a minor in mathematical analysis. Her dissertation was about safety verification and control for cooperative vehicles at road intersections. Her current research interests include the analysis and control of cyber-physical systems.



Jose Amaya *Northern Essex Community College*
Systems & Network Administrator

Jose has over 15 years' experience in various IT support roles in system administration and technical training. His primary interests are working with different open source technologies and research computing services. Northern Essex Community College graduate, certified in computer networking.



Luigi (Lou) Baccari *B.S., University of Massachusetts of Lowell*
Manager Computational & Network Services & Purchasing

Lou has 23 years of experience in the System and Network Administrations field. For the 6 years prior to joining MERL he worked at HP/Compaq's Cambridge Research Labs providing System and Network. Previous to that he worked for Force Computers, Lycos and Digital Equipment Corp. as Data Center Manager and in various System/Network Support roles.



Mouhacine Benosman *Ph.D., Ecole Centrale de Nantes, 2002*
Senior Principal Research Scientist

Before coming to MERL in 2010, Mouhacine worked at universities in Rome, Italy, Reims, France and Glasgow, Scotland before spending 5 years as a Research Scientist with the Temasek Laboratories at the National University of Singapore. His research interests include modeling and control of flexible systems, non-linear robust and fault tolerant control, vibration suppression in industrial machines and multi-agent control with applications to smart-grid.



Karl Berntorp *Ph.D., Lund University, 2014*
Research Scientist

Karl's doctoral research addressed development of particle-filtering methods, and sensor fusion and optimal control applied to vehicles and robots. His research interests are in nonlinear estimation and control, path planning, motion control, and their applications to automotive, robotics, and aerospace systems.



Daniel Birch *Ph.D., University of California, San Diego, 2007*
Visiting Research Scientist

Daniel earned his Ph.D. and did postdoctoral work in oceanography, where he studied mathematical models for plankton distributions and mixing in the ocean. After taking a few years to teach high school physics, Daniel returned to research and currently works on developing innovative lighting technologies at MERL.



Scott A. Bortoff *Ph.D., University of Illinois Urbana-Champaign, 1992*
Strategic Project Leader, Distinguished Research Scientist

Scott's research interests are in applications of nonlinear and optimal control theory to motion control, path planning and process control problems. Before joining MERL in 2009, Scott led the Controls Group at the United Technology Research Center and previously was an Associate Professor at the University of Toronto.



Petros T. Boufounos *Sc.D., Massachusetts Institute of Technology, 2006*
Senior Principal Research Scientist, Team Leader

Petros was a Postdoctoral associate at Rice until Jan. 2009, when he joined MERL. Since joining MERL, Petros has contributed in areas such as high-speed video acquisition, ultrasonic imaging, and privacy-preserving secure embeddings. His interests include signal acquisition and processing, signal representations and compressive sensing. He is also a visiting scholar at Rice University and an Associate Editor of IEEE Signal Processing Letters.



Matthew E. Brand *Ph.D., Northwestern University, 1994*
MERL Fellow

Matt develops and analyzes optimization algorithms for problems in logistics, control, perception, data-mining, and learning. Notable results include methods for parallel solution of quadratic programs, recomposing photos by re-arranging pixels, nonlinear dimensionality reduction, online singular value decomposition, 3D shape-from-video, and learning concise models of data.



Ankush Chakrabarty *Ph.D., Purdue University, 2016*
Visiting Research Scientist

At Purdue, Ankush's research focused on developing scalable, data-driven methods for simplifying computationally intensive operations encountered in controlling and observing complex, nonlinear systems. Prior to joining MERL, Ankush was a postdoctoral Fellow at Harvard where he designed embedded model predictive controllers and deep learning-assisted control strategies for treating people with type 1 diabetes.



Siheng Chen *Ph.D., Carnegie Mellon University, 2016*
Research Scientist

Before coming to MERL, Siheng worked postdoctoral research associate at CMU and on perception and prediction systems for self-driving cars at Uber Advanced Technologies Group. He is the recipient of the 2018 IEEE Signal Processing Society Young Author Best Paper Award. His research interests include graph signal processing, graph neural networks, 3D point cloud processing, and graph mining.



Anoop Cherian *Ph.D., University of Minnesota, 2013*
Research Scientist

Anoop was a postdoctoral researcher in the LEAR group at Inria 2012-2015 where his research was on the estimation and tracking of human poses in videos. 2015-2017, he was a Research Fellow at the Australian National University, where he worked on recognizing human activities in video. Currently, his research focus is on modeling the semantics of video data.



Radu Corcodel *Ph.D., University of Connecticut, 2017*
Visiting Research Scientist

Radu's PhD focused on workspace analysis and motion synthesis for arbitrary kinematic chains, with particular emphasis on robotic 3D printing and Fusion Deposition Modeling. Currently his research focuses on motion planning and workspace analysis for over-actuated kinematic linkages and collaborative robots.



Claus Danielson *Ph.D., University of California, Berkeley, 2008*
Research Scientist

Claus' research interests are in model predictive control, constrained control, and networked control systems. His doctoral research was focused on computational efficiency based on exploiting the symmetry in large-scale control and optimization problems.



Marissa Deegan *M.B.A., Southern New Hampshire University, 2018*
HR Generalist/ Administrator

Marissa joined MERL in 2015. She has experience in various fields as coordinators of customer service and administration departments. Previously, she worked as a Coordinator of Customer Service and Administration in a soccer company for children. Her interests are in human resource management.



Stefano Di Cairano *Ph.D., University of Siena, 2008*
Senior Principal Research Scientist, Optimization Team Leader

Stefano's interests are model predictive control, constrained control, networked control systems, optimization algorithms, stochastic systems, and their applications to automotive, aerospace, logistics, and factory automation. Stefano is a member of the IEEE CSS Conference Editorial Board, and the Chair of the IEEE CSS Technical Committee on Automotive Controls.



Abraham M. Goldsmith *M.S., Worcester Polytechnic Institute, 2008*
Principal Research Scientist

At WPI, Abraham researched 3D ultrasound imaging, particularly the reconstruction of 3D volumes from sequences of 2D images. At MERL he has worked in areas ranging from wireless sensor networks to optical metrology and control of electro-mechanical systems. In addition, Abraham provides electrical and mechanical engineering support to the entire laboratory.



Piyush Grover *Ph.D., Virginia Polytechnic Institute & State Univ., 2010*
Principal Research Scientist

Piyush works at the intersection of dynamical systems, mechanics and control. He is interested in applying geometric and statistical methods for exploiting structure in nonlinear dynamical systems. Areas of applications include low-fuel space mission design, chaotic mixing, model reduction of distributed systems and nonlinear estimation.



Jianlin Guo *Ph.D., University of Windsor, 1995*
Senior Principal Research Scientist

Jianlin worked at Waterloo Maple as a software developer before joining MERL in 1998. His primary research interests include reliable wireless networks, SmartGrid systems, vehicular communications, broadband wireless communications, and embedded systems.



Bret A. Harsham *B.S., Massachusetts Institute of Technology*
Principal Research Scientist

Before joining MERL in 2001, Bret worked at Dragon Systems on handheld and automotive speech products. At MERL, he works on research projects in the area of speech and multimodal applications, with a focus on effectiveness and usability. Past research projects have included work on multi-user touch interfaces and the safety & usability of in-car speech applications.



Hiroyuki Hashimoto *Ph.D., University of Tokyo, 2015*
Liaison Manager

Hiroyuki joined Mitsubishi Electric Corporation in 1995 where he had been engaged in research on electric power grid analysis, stability control, thermal/hydro generation scheduling, power liberalization support system, and smart grid system. He has also researched optimization technology and is interested in applying it to an industrial system. Before joining MERL, he was a Group Manager of power system technology group in the Advanced Technology Research Center.



Chiori Hori *Ph.D., Tokyo Institute of Technology, 2002*
Principal Research Scientist

Prior to joining MERL in 2015, Chiori spent 8 years at Japan's National Institute of Information and Communication Technology (NICT), rising to research manager of the Spoken Language Communication Lab. Chiori's work has focused on speech summarization/translation, spoken dialog technology, and standardization of speech interface communication protocols.



Takaaki Hori *Ph.D., Yamagata University, 1999*
Principal Research Scientist

Before joining MERL in 2015, Takaaki spent 15 years doing research on speech and language technology at Nippon Telegraph, and Telephone in Japan. His work includes speech recognition algorithms using weighted finite-state transducers (WFSTs), efficient search algorithms for spoken document retrieval, spoken language understanding, and automatic meeting analysis.



Frederick J. Igo, Jr. *B.A., Le Moyne College, 1982*
Senior Principal Member Research Staff

Fred's professional interests are in software development and its process. He joined MERL in 1985 and has worked on various software technologies, including Distributed Computing, Distributed OLTP, Message Queuing, Mobile Agents, Data Mining, ZigBee, reliable wireless protocols and web development. Prior to joining MERL Fred worked at IPL Systems.



Devesh Jha *Ph.D., Pennsylvania State University, 2016*
Research Scientist

Devesh's PhD Thesis was on decision & control of autonomous systems. He also got a Master's degree in Mathematics from Penn State. His research interests are in the areas of Machine Learning, Time Series Analytics and Robotics. He was a recipient of the best student paper award at the 1st ACM SIGKDD workshop on Machine Learning for Prognostics and Health Management at KDD 2016, San Francisco.



Michael J. Jones *Ph.D., Massachusetts Institute of Technology, 1997*
Senior Principal Research Scientist

Mike's main interest is in computer vision, machine learning and data mining. He has focused on algorithms for detecting and analyzing people in images and video including face detection/recognition and pedestrian detection. He is co-inventor of the popular Viola-Jones face detection method. Mike received the Marr Prize at ICCV and the Longuet-Higgins Prize at CVPR.



Uros Kalabic *Ph.D., University of Michigan, 2015*
Research Scientist

Uros works on advancements in the theory of predictive control and constrained control, as well as its applications to the control of automotive and aerospace systems. His dissertation dealt with theoretical developments and practical applications of reference governors. Prior to joining MERL, Uros interned at MERL and at Ford Motor Company.



Kyeong Jin Kim *Ph.D., University of California Santa Barbara, 2000*
Senior Principal Research Scientist

Kyeong Jin's research interests include transceiver design, performance analysis of spectrum sharing systems, design of cooperative communication systems. Since joining MERL, he has contributed in areas such as reliable communications and E-WLAN system. Currently he is an Associate Editor of IEEE Communications Letters.



Toshiaki Koike-Akino *Ph.D., Kyoto University, 2005*
Senior Principal Research Scientist

Prior to joining MERL in 2010, Toshiaki was a postdoctoral researcher at Harvard University. His research interests include signal processing, cooperative communications, coding theory, and information theory. He received best paper awards at IEEE GLOBECOM in 2008 and 2009.



Keisuke Kojima *Ph.D., University of Tokyo, 1990*
Senior Principal Research Scientist

During his 8 years at the Central Research Laboratory, Mitsubishi Electric Corp. (Amagasaki, Japan), and 13 years AT&T/Lucent Bell Laboratories and other major US companies, Keisuke worked on R&D of semiconductor lasers and optical systems as a technical staff and later as a manager. At MERL he is currently working on simulations of optical devices and systems. He has more than 100 publications in journals and conference proceedings.



Emil Laftchiev *Ph.D., Pennsylvania State University, 2015*
Research Scientist

Emil's research interests are in the identification of efficient storage methods using dimension reducing data features. The purpose of this research is to enable rapid continuous localization within the data. Prior to joining MERL Emil served as a Distinguished Teaching Fellow for the College of Engineering at the Pennsylvania State University.



Christopher Laughman *Ph.D., Massachusetts Institute Technology, 2008*
Senior Principal Research Scientist, Team Leader

Christopher's interests lie in the intersection of the modeling of physical systems and the experimental construction and testing of these systems, including simulation, numerical methods, and fault detection. He has worked on a variety of multi-physical systems, such as thermo-fluid systems and electromechanical energy conversion systems.



Jonathan Le Roux *Ph.D., University of Tokyo, 2009*
Senior Principal Research Scientist, Team Leader

Jonathan completed his B.Sc. and M.Sc. in Mathematics at the Ecole Normale Supérieure in Paris, France. Before joining MERL in 2011, he spent several years in Beijing and Tokyo. In Tokyo he worked as a postdoctoral researcher at NTT's Communication Science Laboratories. His research interests are in signal processing and machine learning applied to speech and audio.



Teng-Yok Lee *Ph.D., Ohio State University, 2011*
Research Scientist

Teng-Yok's research interests are visual (computer graphics, visualization, and image processing) and computational (GPU, high performance and cloud computing). His PhD studies were about the visualization of scientific results, especially time-varying and Computational Fluid Dynamics (CFD) data.



Chungwei Lin *Ph.D., Columbia University, 2008*
Research Scientist

Before joining MERL, Chungwei was a postdoctoral researcher in the Physics Department of the University of Texas at Austin. His particular interest is the use of doping/interface to control optical, thermal, and transport properties. He has worked on the theory of self-assembly, configuration interaction quantum impurity solvers, and photoemission spectroscopy.



Dehong Liu *Ph.D., Tsinghua University, 2002*
Senior Principal Research Scientist

Prior to joining MERL in 2010, Dehong worked at Duke University as a post-doctoral Research Associate (2003-2008), Research Scientist (2008-2010) and Sr. Research Scientist (2010). His main research interests include compressive sensing, signal processing and machine learning.



Rui Ma *Ph.D., University of Kassel, 2009*
Senior Principal Research Scientist

Prior to joining MERL, Rui was a Senior Power Amplifier Research Engineer at Nokia Siemens Networks. His research interests include RF Power Device Modeling, Power Amplifier / Radio Front-End Architectures, non-linear microwave circuit design and high frequency measurement techniques.



Yanting Ma *Ph.D., North Carolina State University, 2017*
Research Scientist

Yanting's research interests are mainly in algorithm design and analysis for inverse problems arising in computational sensing using statistical inference and optimization techniques. Her PhD research focused on algorithmic and theoretical studies of approximate message passing, as well as provably convergent optimization algorithms for nonlinear diffractive imaging. Her postdoctoral work developed principled methods for dead time compensation for single-photon detectors based on Markov chain modeling.



Hassan Mansour, *Ph.D. University of British Columbia, 2009*
Principal Research Scientist

Hassan's research interests are in video compression, video transmission and compressed sensing. His PhD research developed resource allocation schemes for the transmission of scalable video content over bandwidth constrained wireless networks. Subsequent work developed adaptive sparse recovery algorithms for correlated signals from compressive measurements.



Tim K. Marks *Ph.D., University of California San Diego, 2006*
Senior Principal Research Scientist

Prior to joining MERL's Imaging Group in 2008, Tim did postdoctoral research in robotic Simultaneous Localization and Mapping in collaboration with NASA's Jet Propulsion Laboratory. His research at MERL spans a variety of areas in computer vision and machine learning, including face recognition under variations in pose and lighting, and robotic vision and touch-based registration for industrial automation.



James McAleenan *J.D., Hamline University Law School, 1999*
Patent Counsel

Jim is a registered patent attorney and former U.S. Patent Examiner with more than 16 years of experience in patent and Intellectual Property law. Jim has held in-house legal roles at significant U.S. and multinational companies, having served as Senior Patent Counsel and Senior Intellectual Property Attorney.



Kathleen McCarthy *B.A., Boston College, 1992*
Controller

Kathleen has worked for over 30 years in the Accounting field with experience in general accounting, payroll and property management. Prior to joining MERL in 1993, she worked in manufacturing, financial and service industries.



Kerry McKeon *B.A., Saint Michael's College, 2010*
Lab Administrator

Kerry has her BA in Psychology and is currently pursuing a masters in Licensed Mental Health Counseling. Kerry has experience in various fields working as a service coordinator and developmental specialist with families and children. Her interests are in human development research, specifically on the impact of societal changes on development throughout the years.



David S. Millar *Ph.D., University College London (UCL), 2011*
Principal Research Scientist

Before joining MERL, David was a postdoctoral researcher at UCL, working on DSPs for coherent optical fiber transmission. Since then, he has been working on next generation systems and subsystems for the physical layer. He is particularly interested in advanced modulation formats, algorithms for equalization & carrier recovery, and reduced complexity transponders.



Francis Morales *B.S., Universidad APEC (Dominican Republic), 2007*
Systems & Network Administrator

Francis has been in the IT field since 2001 with experience in different IT industries with special interest in OSs, Networking and Security. Prior to joining MERL he worked 4 years in the healthcare IT field. Previous to that, he was the principal of a small Computer Service business in his home country.



Niko Moritz *Ph.D., University of Oldenburg, 2016*
Visiting Research Scientist

Niko's research interests are in automatic speech recognition and machine learning with application to acoustic events and speech. Prior to joining MERL in 2018, Niko spent 9 years at the Hearing, Speech and Audio (HSA) Technology branch of the Fraunhofer IDMT in Oldenburg (Germany) doing R&D to build automatic speech recognition systems.



Saleh Nabi *Ph.D., University of Alberta, 2014*
Adjunct Research Scientist

Saleh's research interests are analytical, numerical and similitude experimental modeling of fluid flow and heat transfer in complex systems. His ambition is to derive reduced order models for turbulent buoyancy-driven flows in confined regions to reduce the simulation run time by several orders of magnitude. Saleh's doctoral research mainly focused on environmental and architectural fluid mechanics applied to airflow modeling.

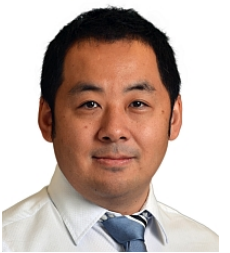

Yukimasa (Yuki) Nagai *M.S., University of Electro-Communications, 2000*
Liaison Manager

Yuki joined Mitsubishi Electric Corporation in 2000 where he has been engaged in research on wireless communication, connected cars, V2X and Vehicle IoT. Before joining MERL, he was an active participant in the IEEE 802.11, 15 & 19 standardization efforts, the Wi-Fi Alliance and JasPar. He has been the vice chair of the Automotive Market Segment Task Group and the DSRC Marketing Task Group in the Wi-Fi Alliance since 2013.



Daniel N. Nikovski *Ph.D., Carnegie Mellon University, 2002*
Data Analytics Group Manager

Dan's research is focused on algorithms for reasoning, planning, and learning with probabilistic models. His current work is on the application of such algorithms to hard transportation problems such as group elevator control and traffic prediction. He also has varied interests in the field of data mining.



Philip V. Orlik *Ph.D., State University of New York at Stony Brook, 1999*
Electronics & Communications Group Manager

Prior to joining MERL in 2000, Phil worked as a simulation engineer for the MITRE Corporation. His current research interests include wireless communications and networking, signal processing for communication systems, queuing theory, and analytical modeling.



Milutin Pajovic *Ph.D., Massachusetts Institute of Technology, 2014*
Principal Research Scientist

Milutin's doctoral thesis studied adaptive signal processing with deficient sample support using random matrix theory methods and considered adaptive sensor array processing, channel estimation and channel equalization as specific applications. His interests also include communications, statistical signal processing and machine learning.



Kieran Parsons *Ph.D., University of Bristol, UK, 1996*
Senior Principal Research Scientist, Optical Team Leader

Kieran spent 12 years in Canada working at Nortel, BelAir Networks and AMCC on the system design of several wireless and optical technologies, including early work on electronic dispersion compensation for optical links. His research interests include optical communications network architecture and digital signal processing algorithms for coherent optical communications.



Ronald N. Perry *B.Sc., Bucknell University, 1981*
Distinguished Research Scientist

Ron's fundamental research in computer graphics has resulted in numerous publications, a comprehensive patent portfolio, and the development of several meticulously crafted software and hardware products. Ron is best known for the Saffron Type System. The other highlight of his research is the development of 3D ADFs for CAD related products, including an NC simulation system demonstrating unprecedented precision and compactness.



Kristin Peterson *B.S., Towson University, 2007*
Patent Paralegal

Kristin joined MERL in 2012 as a Patent assistant. Prior to working at MERL she attended Boston University's Paralegal program to support a career change. She previously held a position in hospital finance and was a Realtor in the Maryland metropolitan area. She has a Bachelor of Science degree in Psychology.



Hongtao Qiao *Ph.D., University of Maryland, 2014*
Research Scientist

Prior to his PhD, Hongtao worked at Carrier Corporation developing advanced steady-state computer simulations for HVAC systems. During his PhD, he developed a comprehensive transient modeling framework for thermo-fluid systems to explore complex dynamic characteristics of vapor compression cycles.



Rien Quirynen *Ph.D., KU Leuven and University of Freiburg, 2017*
Research Scientist

Rien's research interests are in model predictive control and moving horizon estimation, numerical algorithms for (nonlinear) dynamic optimization and real-time control applications. His doctoral research was focused on numerical simulation methods with efficient sensitivity propagation for real-time optimal control algorithms.



Arvind U. Raghunathan *Ph.D., Carnegie Mellon University, 2004*
Senior Principal Research Scientist

Arvind's research focuses on optimization algorithms large-scale and mixed integer nonlinear programs with applications in power grid, transportation systems and model-based control of processes. He previously worked at the United Technologies Research Center for 7 years developing optimization algorithms for aerospace, elevator, and energy systems.



Diego Romeres *Ph.D., University of Padova, 2017*
Research Scientist

Diego's research interests are in machine learning, system identification and robotic applications. At MERL he is currently working on applying nonparametric machine learning techniques for the control of robotic platforms. His Ph.D. thesis is about the combination of nonparametric data-driven models and physics-based models in gaussian processes for robot dynamics learning.



Koji Sakai *M.S., Kobe University, 2008*
Liaison Manager

Koji joined Mitsubishi Electric Corporation in 2016 and has been working in the area of Intellectual Property. Prior to joining Mitsubishi Electric in 2016, he worked at Toshiba in the same area.



Thiago Serra *Ph.D., Carnegie Mellon University, 2018*
Visiting Research Scientist

Thiago's research focuses on theory and applications of decision diagrams, deep learning, and integer programming. Between 2009 and 2013, he worked at Petrobras on scheduling algorithms to optimize offshore oil well developments. He received the Judith Liebman Award from INFORMS in 2016 and the Gerald L. Thompson Doctoral Dissertation Award in Management Science from Carnegie Mellon University in 2018.



Alan Sullivan *Ph.D., University of California at Berkeley, 1993*
Computer Vision Group Manager

First at U.C. Berkeley, then at Lawrence Livermore National Laboratory, Alan studied interactions between ultra-high intensity femtosecond lasers and plasmas. Prior to joining MERL in 2007, he worked at a series of start-ups where he developed a novel volumetric 3D display technology. At MERL His research interests include computational geometry and computer graphics.



Hongbo Sun *Ph.D., Chongqing University, 1991*
Senior Principal Research Scientist

Prior to Joining MERL in 2010, Hongbo was a principal applications Engineer at Oracle, and a technical architect at SPL WorldGroup. He is a registered Professional Engineer with more than 20 years' experience in technical consulting, product development and research on electrical transmission and distribution system planning, analysis, and automation.



Huifang Sun *Ph.D., University of Ottawa, 1986*
MERL Fellow, IEEE Fellow

After four years as a Professor at Fairleigh Dickinson University, Huifang moved to the Sarnoff Research Laboratory in 1990 becoming Technology Leader for Digital Video Communication. In 1995, Huifang joined MERL as the leader of MERL's video efforts. In recognition of his productive career in video processing, Huifang was made an IEEE Fellow in 2001.



Koon Hoo Teo *Ph.D., University of Alberta 1990*
Senior Principal Research Scientist, Power & Devices Team Leader

Koon Hoo was with Nortel for 15 years where he was actively involved in the research and implementation of 3G and 4G wireless systems. His work at MERL includes Cognitive Radio, Game Theory and Wireless Mesh for WiMAX and LTE systems. His current areas of research include Metamaterials, Power Amplifiers and Power Devices.



Jay E. Thornton *Ph.D., University of Michigan, 1982*
Mechatronics Group Manager

Prior to joining MERL in 2002, Jay worked at Polaroid Corporation for many years on human vision and image science problems concerning color reproduction, image quality, half toning, and image processing. At MERL he has become absorbed in research on vision for robotics, medical imaging, computational photography, computer human observation, dictionary learning, and processing of the 3D world.



Hironori Tsukamoto *Ph.D., Tokyo Institute of Technology, 1999*
Patent Agent

Tsukamoto worked as a research scientist in the area of silicon and compound semiconductor materials/devices at Sony Research Center and Yale University for more than 15 years. Prior to joining MERL, he worked at a Japanese Patent Firm to support US patent practice of Japanese client companies for more than 5 years.



Jeroen van Baar *Ph.D., ETH Zurich, 2013*
Senior Principal Research Scientist

Jeroen came to MERL in 1997 as an intern, and was subsequently hired as research associate. He temporarily left MERL to pursue a Ph.D. and returned early 2013. At MERL he has made contributions in the areas of computer graphics, computer vision and computational photography. His interests include 3D reconstruction, medical imaging, GP-GPU for computational photography and computer vision.



Gene V. Vinokur *J.D., Suffolk University Law School, 2011*
Senior Patent Counsel

Gene graduated cum laude with distinction in Intellectual Property law. In addition, he holds advanced degrees in Mechanical Engineering and Computer Science. He is a member of Massachusetts Bar and has been a licensed patent practitioner since 2003.



Bingnan Wang *Ph.D., Iowa State University 2009*
Principal Research Scientist

Bingnan's doctoral work focused on the study of wave propagation in novel electromagnetic materials, including photonic crystals and meta-materials. His research interests include electromagnetics and photonics, and their applications to communications, imaging, and energy systems.



Pu Wang *Ph.D., Stevens Institute of Technology, 2011*
Principal Research Scientist

Before coming to MERL, Pu was a Research Scientist in the Mathematics and Modeling Department of Schlumberger-Doll Research, contributing to development of logging-while-drilling Acoustic/NMR products. His current research interests include statistical signal processing, Bayesian inference, sparse signal recovery, and their applications to sensing, wireless communications, and networks.

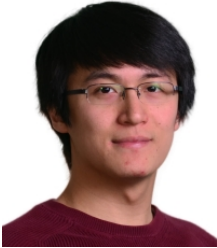

Ye Wang *Ph.D., Boston University, 2011*
Principal Research Scientist

Ye was a member of the Information Systems and Sciences Laboratory at Boston University, where he studied information-theoretically secure multiparty computation. His current research interests include information security, biometric authentication, and data privacy.



Yebin Wang *Ph.D., University of Alberta, 2008*
Senior Principal Research Scientist

Prior to joining MERL, Yebin worked on process control, software development and management, and nonlinear estimation theory for over ten years. Yebin's research interests include nonlinear estimation/control theory and applications, optimal control, adaptive/learning systems, modeling and control of complex systems.



Avishai Weiss *Ph.D., University of Michigan, 2013*
Research Scientist

Avishai's doctoral research was on spacecraft orbital and attitude control. Prior to the University of Michigan, he studied at Stanford University, where he received a B.S. in Electrical Engineering and an M.S. in Aeronautics and Astronautics. Avishai's interests are in constrained control, model predictive control, and time-varying systems.



Gordon Wichern *Ph.D., Arizona State University, 2010*
Principal Research Scientist

Gordon's research interests are at the intersection of signal processing and machine learning applied to speech, music, and environmental sounds. Prior to joining MERL, Gordon worked at iZotope inc. developing audio signal processing software, and at MIT Lincoln Laboratory where he worked in radar target tracking.



Victoria Wong *B.S. Bentley College, 2008*
Principal Staff Accountant

Victoria has over 10 years' experience primarily focusing on accounts payable and payroll. She joined MERL in June, 2008. Prior to joining MERL, she was an intern with Federal Reserve Bank of Boston and EF Education. Her B.S. degree is in Accounting Information Systems.



William S. Yerazunis *Ph.D., Rensselaer Polytechnic Institute, 1987*
Senior Principal Research Scientist

Bill has worked in numerous fields, including parallel computation, SETI, jet engine production, real-time signal processing, expert systems, pattern recognition, text classification, wireless power, and meta-materials. He is the author of the CRM114 spam filter, and was voted one of the 50 most important people in computer network security by Network World magazine.



Jing Zhang *Ph.D., Boston University, 2017*
Research Scientist

Jing's PhD dissertation was on detection and optimization problems with applications in transportation systems. His research interests include anomaly detection, optimization, machine learning, and time series analysis. He was a recipient of the Boston Area Research Initiative (BARI) Research Seed Grant Award (Spring 2017).



Ziming Zhang *Ph.D., Oxford Brookes University, 2013*
Research Scientist

Before joining MERL he was a research assistant professor at Boston University, MA. His research interest lies in computer vision and machine learning, including object recognition and detection, zero-shot learning, optimization, etc. His works have appeared in TPAMI, CVPR, ICCV, ECCV, ACM MM and NIPS.

Publications

The following lists the major publications by members of the MERL staff during the period of this report. A publication is considered major if it appeared in a refereed journal, a refereed conference proceeding or some other significant publication such as a book.

Ozdenizci, O.; Wang, Y.; Koike-Akino, T.; Erdogmus, D., “**Adversarial Deep Learning in EEG Biometrics**”, *IEEE Signal Processing Letters*, DOI: 10.1109/LSP.2019.2906826, vol. 26, pp. 710-714, March 2019 ([TR2019-017](#))

Bergman, D.; Cardonha, C.; Cire, A.; Raghunathan, A.U., “**On the Minimum Chordal Completion Polytope**”, *Operations Research*, DOI: 10.1287/opre.2018.1783, vol. 67, pp. 295-597, March 2019 ([TR2018-095](#))

Ozdenizci, O.; Wang, Y.; Koike-Akino, T.; Erdogmus, D., “**Transfer Learning in Brain-Computer Interfaces with Adversarial Variational Autoencoders**”, *International IEEE EMBS Conference on Neural Engineering*, DOI: 10.1109/NER.2019.8716897, March 2019 ([TR2018-184](#))

Wei, C.-S.; Koike-Akino, T.; Wang, Y., “**Spatial Component-wise Convolutional Network (SCCNet) for Motor-Imagery EEG Classification**”, *International IEEE EMBS Conference on Neural Engineering*, DOI: 10.1109/NER.2019.8716937, March 2019 ([TR2018-210](#))

Le Roux, J.; Wichern, G.; Watanabe, S.; Sarroff, A.; Hershey, J., “**Phasebook and Friends: Leveraging discrete representations for source separation**”, *IEEE Journal of Selected Topics in Signal Processing*, DOI: 10.1109/JSTSP.2019.2904183, vol. 13, pp. 370-382, March 2019 ([TR2018-199](#))

Bakshi, K.; Grover, P.; Theodorou, E., “**On Mean Field Games for Agents with Langevin Dynamics**”, *IEEE Transactions on Control of Network Systems*, DOI: 10.1109/TCNS.2019.2896975, March 2019 ([TR2018-200](#))

Romeres, D.; Zorzi, M.; Camoriano, R.; Traversaro, S.; Chiuso, A., “**Derivative-free online learning of inverse dynamics models**”, *IEEE Transactions on Control Systems Technology*, DOI: 10.1109/TCST.2019.2891222, March 2019 ([TR2018-201](#))

d'Haro, L.F.; Banchs, R.; Hori, C.; Li, H., “**Automatic Evaluation of End-to-End Dialog Systems with Adequacy-Fluency Metrics**”, *Special issue on DSTC6 in Computer Speech and Language*, DOI: 10.1016/j.csl.2018.12.004, vol. 55, pp. 200-215, March 2019 ([TR2018-195](#))

Bortoff, S.A.; Laughman, C.R., “**An Extended Luenberger Observer for HVAC Application using FMI**”, *International Modelica Conference*, March 2019 ([TR2018-205](#))

Otter, M.; Elmqvist, H.; Zimmer, D.; Laughman, C.R., “**Thermodynamic Property and Fluid Modeling with Modern Programming Language Constructs**”, *International Modelica Conference*, March 2019 ([TR2018-203](#))

Li, Z.; Qiao, H.; Aute, V., “**Tube-fin Heat Exchanger Circuitry Optimization For Improved Performance Under Frosting Conditions**”, *International Modelica Conference*, DOI: 10.3384/ecp19157259, March 2019 ([TR2018-212](#))

Qiao, H.; Nabi, S.; Han, X.; Laughman, C.R., “**Coupled Simulation of a Room Air-conditioner with CFD Models for Indoor Environment**”, *International Modelica Conference*, March 2019 ([TR2018-211](#))

Bortoff, S.A., “**Using Baumgarte's Method for Index Reduction in Modelica**”, *International Modelica Conference*, March 2019 ([TR2018-204](#))

Matsumine, T.; Koike-Akino, T.; Millar, D.S.; Kojima, K.; Parsons, K., “**Polar-Coded Modulation for Joint Channel Coding and Probabilistic Shaping**”, *Optical Fiber Communication Conference and Exposition and the National Fiber Optic Engineers Conference (OFC/NFOEC)*, DOI: 10.1364/OFC.2019.M4B.2, March 2019 ([TR2018-190](#))

Cayci, S.; Koike-Akino, T.; Wang, Y., “**Nonbinary Polar Coding for Multilevel Modulation**”, *Optical Fiber Communication Conference and Exposition and the National Fiber Optic Engineers Conference (OFC/NFOEC)*, DOI: 10.1364/OFC.2019.W3H.4, March 2019 ([TR2018-191](#))

Fehenberger, T.; Millar, D.S.; Koike-Akino, T.; Kojima, K.; Parsons, K., “**Partition-Based Probabilistic Shaping for Fiber-Optic Communication Systems**”, *Optical Fiber Communication Conference and Exposition and the National Fiber Optic Engineers Conference (OFC/NFOEC)*, DOI: 10.1364/OFC.2019.M4B.3, March 2019 ([TR2018-189](#))

TaherSima, M.; Kojima, K.; Koike-Akino, T.; Jha, D.; Wang, B.; Lin, C.; Parsons, K., “**Deep Neural Network Inverse Modeling for Integrated Photonics**”, *Optical Fiber Communication Conference and Exposition and the National Fiber Optic Engineers Conference (OFC/NFOEC)*, DOI: 10.1364/OFC.2019.W3B.5, March 2019 ([TR2018-183](#))

Xu, H.; Sun, H.; Nikovski, D.N.; Shoichi, K.; Mori, K., “**Learning Dynamical Demand Response Model in Real-Time Pricing Program**”, *IEEE Innovative Smart Grid Technologies North America (ISGT NA)*, February 2019 ([TR2018-198](#))

Benosman, M.; Farahmand, A.-M.; Xia, M., “**Learning-Based Iterative Modular Adaptive Control for Nonlinear Systems**”, *International Journal of adaptive control and signal processing*, DOI: 10.1002/acs.2892, vol. 33, pp. 335-355, February 2019 ([TR2018-108](#))

Cherian, A.; Sullivan, A., “**Sem-GAN: Semantically-Consistent Image-to-Image Translation**”, *IEEE Winter Conference on Applications of Computer Vision (WACV)*, DOI: 10.1109/WACV.2019.00196, January 2019 ([TR2018-178](#))

Mansour, H.; Liu, D.; Kamilov, U.; Boufounos, P.T., “**Sparse Blind Deconvolution for Distributed Radar Autofocus Imaging**”, *IEEE Transactions on Image Processing*, DOI: 10.1109/TCI.2018.2875375, vol. 4, pp. 537-551, December 2018 ([TR2018-179](#))

Zhan, J.; Jiang, Z.-P.; Wang, Y.; Li, X., “**Distributed Model Predictive Consensus With Self-triggered Mechanism in General Linear Multi-agent Systems**”, *IEEE Transactions on Industrial Informatics*, DOI: 10.1109/TII.2018.2884449, December 2018 ([TR2018-182](#))

Berntorp, K.; Di Cairano, S., “**Noise-Statistics Learning of Automotive-Grade Sensors Using Adaptive Marginalized Particle Filtering**”, *Journal of Dynamic Systems, Measurement, and Control*, DOI: 10.1115/1.4042673, vol. 141, December 2018 ([TR2018-181](#))

TaherSima, M.; Kojima, K.; Koike-Akino, T.; Jha, D.; Wang, B.; Lin, C.; Parsons, K., “**Deep Neural Network Inverse Design of Integrated Photonic Power Splitters**”, *Nature Scientific Reports*, December 2018 ([TR2018-180](#))

Khodkar, A.; Hassanzadeh, P.; Nabi, S.; Grover, P., “**Reduced-order modeling of fully turbulent buoyancy-driven flows using the Green's function method**”, *Physical Review Fluids*, DOI: 10.1103/PhysRevFluids.4.013801, vol. 4, December 2018 ([TR2018-170](#))

Fehenberger, T.; Millar, D.S.; Koike-Akino, T.; Kojima, K.; Parsons, K., “**Multiset-Partition Distribution Matching**”, *IEEE Transactions on Communications*, DOI: 10.1109/TCOMM.2018.2881091, December 2018 ([TR2018-168](#))

Hayashi, T.; Watanabe, S.; Zhang, Y.; Toda, T.; Hori, T.; Astudillo, R.; Takeda, K., “**Back-Translation-Style Data Augmentation for End-to-End ASR**”, *IEEE Spoken Language Technology Workshop*, DOI: 10.1109/SLT.2018.8639619, December 2018 ([TR2018-174](#))

Cho, J.; Baskar, M.K.; Li, R.; Wiesner, M.; Mallidi, S.H.; Yalta, N.; Karafiat, M.; Watanabe, S.; Hori, T., “**Multilingual Sequence-to-Sequence Speech Recognition: Architecture, Transfer Learning, and Language Modeling**”, *IEEE Spoken Language Technology Workshop*, DOI: 10.1109/SLT.2018.8639655, December 2018 ([TR2018-175](#))

Hori, T.; Cho, J.; Watanabe, S., “**End-to-End Speech Recognition with Word-Based RNN Language Models**”, *IEEE Spoken Language Technology Workshop*, DOI: 10.1109/SLT.2018.8639693, December 2018 ([TR2018-176](#))

Berntorp, K.; Danielson, C.; Weiss, A.; Di Cairano, S., “**Positive Invariant Sets for Safe Integrated Vehicle Motion Planning and Control**”, *IEEE Annual Conference on Decision and Control (CDC)*, DOI: 10.1109/CDC.2018.8619458, December 2018 ([TR2018-172](#))

Nilsson, G.; Grover, P.; Kalabic, U., “**Assignment and Control of Two-Tiered Vehicle Traffic**”, *IEEE Conference on Decision and Control (CDC)*, DOI: 10.1109/CDC.2018.8619411, December 2018 ([TR2018-171](#))

Chakrabarty, A.; Raghunathan, A.U.; Di Cairano, S.; Danielson, C., “**Data-Driven Estimation of Reachable and Invariant Sets for Unmodeled Systems via Active Learning**”, *IEEE Conference on Decision and Control (CDC)*, DOI: 10.1109/CDC.2018.8619646, December 2018 ([TR2018-187](#))

Ma, Y.; Wang, Y.; Di Cairano, S.; Koike-Akino, T.; Guo, J.; Orlik, P.V.; Lu, C., “**A smart actuation architecture for wireless networked control systems**”, *IEEE Conference on Decision and Control (CDC)*, DOI: 10.1109/CDC.2018.8619831, December 2018 ([TR2018-177](#))

Fang, H.; Haile, M.; Wang, Y., “**Robustifying the Kalman Filter against Measurement Outliers: An Innovation Saturation Mechanism**”, *IEEE Conference on Decision and Control (CDC)*, DOI: 10.1109/CDC.2018.8619140, December 2018 ([TR2018-173](#))

Kim, K.J.; Liu, H.; Renzo, M.D.; Poor, H.V., “**Performance Analysis of Spectrum Sharing Systems with Distributed CDD**”, *IEEE Global Communications Conference (GLOBECOM)*, DOI: 10.1109/GLOCOM.2018.8647728, December 2018 ([TR2018-162](#))

Koike-Akino, T.; Wang, P.; Orlik, P.V., “**Joint Lattice and Subspace Vector Perturbation with PAPR Reduction for Massive MU-MIMO Systems**”, *IEEE Global Communications Conference (GLOBECOM)*, DOI: 10.1109/GLOCOM.2018.8647187, December 2018 ([TR2018-163](#))

Pajovic, M.; Ozcan, G.; Koike-Akino, T.; Wang, P.; Orlik, P.V., “**Packet Separation in Phase Noise Impaired Random Access Channel**”, *IEEE Global Communications Conference (GLOBECOM)*, DOI: 10.1109/GLOCOM.2018.8647403, December 2018 ([TR2018-167](#))

Hori, T.; Wang, W.; Koji, Y.; Hori, C.; Harsham, B.A.; Hershey, J., “**Adversarial Training and Decoding Strategies for End-to-end Neural Conversation Models**”, *Computer Speech and Language*, DOI: 10.1016/j.csl.2018.08.006, vol. 54, pp. 122-139, December 2018 ([TR2018-161](#))

Wang, Y.; Zhou, L.; Bortoff, S.A.; Satake, A.; Furutani, S., “**An approximate high gain observer for speed-sensorless estimation of induction motors**”, *IEEE/CAA Journal of Automatica Sinica*, DOI: 10.1109/JAS.2018.7511252, vol. 6, pp. 53-63, December 2018 ([TR2018-155](#))

Zhao, Y.; Wang, Y.; Zhou, M.; Wu, J., “**Energy-Optimal Collision-Free Motion Planning for Multi-Axis Motion Systems: An Alternating Quadratic Programming Approach**”, *IEEE Transactions on Automation Science and Engineering*, DOI: 10.1109/TASE.2018.2864773, vol. 16, pp. 327-338, December 2018 ([TR2018-160](#))

Berntorp, K.; Hoang, T.; Di Cairano, S., “**Motion Planning of Autonomous Road Vehicles by Particle Filtering**”, *IEEE Transactions on Intelligent Vehicles*, DOI: DOI: 10.1109/TIV.2019.2904394, vol. 4, pp. 197-210, December 2018 ([TR2018-164](#))

Kim, K.J.; Liu, H.; Renzo, M.D.; Orlik, P.V.; Poor, H.V., “**Secrecy Analysis of Distributed CDD-Based Cooperative Systems with Deliberate Interference**”, *IEEE Transactions on Wireless Communications*, DOI: 10.1109/TWC.2018.2871200, vol. 17, pp. 7865-7878, December 2018 ([TR2018-159](#))

- Romeres, D.; Jha, D.; Dalla Libera, A.; Chiuso, A.; Nikovski, D.N., “**Derivative-Free Semiparametric Bayesian Models for Robot Learning**”, *Advances in Neural Information Processing Systems (NIPS)*, December 2018 ([TR2018-165](#))
- Kao, C.-C.; Lee, T.-Y.; Sen, P.; Liu, M.-Y., “**Localization-Aware Active Learning for Object Detection**”, *Asian Conference on Computer Vision (ACCV)*, December 2018 ([TR2018-166](#))
- Paul, S.; van Baar, J., “**Trajectory-based Learning for Ball-in-Maze Games**”, *Imitation Learning and its Challenges in Robotics - NIPS*, December 2018 ([TR2018-158](#))
- Jha, D.; Romeres, D.; van Baar, J.; Sullivan, A.; Nikovski, D.N., “**Learning Tasks in a Complex Circular Maze Environment**”, *Modeling the Physical World: Perception, Learning, and Control, NIPS Workshop*, December 2018 ([TR2018-169](#))
- Chung, S.; Ma, R., “**Cancelling Noise in Multi-Band Digital-Intensive Transmitters**”, *Asia-Pacific Microwave Conference*, DOI: 10.23919/APMC.2018.8617217, November 2018 ([TR2018-157](#))
- Wang, B.; Lin, C.; Teo, K.H., “**Coupled-Mode Analysis for Near-Field Thermal Radiation Devices**”, *Biennial IEEE Conference on Electromagnetic Field Computation (CEFC)*, October 2018 ([TR2018-154](#))
- Pajovic, M.; Orlik, P.V.; Wada, T., “**Remaining Useful Life Estimation of Batteries using Dirichlet Process with Variational Bayes Inference**”, *Annual Conference of IEEE Industrial Electronics Society (IECON)*, DOI: 10.1109/IECON.2018.8592767, October 2018 ([TR2018-152](#))
- Laughman, C.R.; Qiao, H., “**On Closure Relations for Dynamic Vapor Compression Cycle Models**”, *American Modelica Conference*, October 2018 ([TR2018-153](#))
- Boufounos, P.T., “**High-Resolution Lidar Using Random Demodulation**”, *IEEE International Conference on Image Processing (ICIP)*, DOI: 10.1109/ICIP.2018.8451424, October 2018 ([TR2018-138](#))
- Yu, X.; Chaturvedi, S.; Feng, C.; Taguchi, Y.; Lee, T.-Y.; Fernandes, C.; Ramalingam, S., “**VLASE: Vehicle Localization by Aggregating Semantic Edges**”, *IEEE/RSJ International Conference on Intelligent Robots and Systems (IROS)*, DOI: 10.1109/IROS.2018.8594358, pp. 3196-3203, October 2018 ([TR2018-113](#))
- Jha, D., “**Algorithms for Task Allocation in Homogeneous Swarm of Robots**”, *IEEE/RSJ International Conference on Intelligent Robots and Systems (IROS)*, DOI: 10.1109/IROS.2018.8594052, October 2018 ([TR2018-151](#))
- Ataer-Cansizoglu, E.; Jones, M.J., “**Super-resolution of Very Low-Resolution Faces from Videos**”, *British Machine Vision Conference (BMVC)*, September 2018 ([TR2018-140](#))

Koike-Akino, T.; Pajovic, M.; Millar, D.S.; Kojima, K.; Parsons, K., “**Superchannel CPE with Wyner-Ziv Cooperation for Band-Limited Interconnects in Multi-DSP Receiver**”, *European Conference on Optical Communication (ECOC)*, DOI: 10.1109/ECOC.2018.8535528, September 2018 ([TR2018-149](#))

Koike-Akino, T.; Millar, D.S.; Parsons, K.; Kojima, K., “**Schalkwijk-Kailath Feedback Error Correction for Optical Data Center Interconnects**”, *European Conference on Optical Communication (ECOC)*, DOI: 10.1109/ECOC.2018.8535184, September 2018 ([TR2018-147](#))

Koike-Akino, T.; Millar, D.S.; Kojima, K.; Parsons, K., “**Lattice Precoding for Multi-Span Constellation Shaping**”, *European Conference on Optical Communication (ECOC)*, DOI: 10.1109/ECOC.2018.8535346, September 2018 ([TR2018-150](#))

Koike-Akino, T.; Wang, Y.; Kojima, K.; Millar, D.S.; Parsons, K., “**EXIT Convergence Analysis of BICM-ID Based on High-Dimensional Modulation and Polar-TPC**”, *European Conference on Optical Communication (ECOC)*, DOI: 10.1109/ECOC.2018.8535499, September 2018 ([TR2018-148](#))

Alvarado, A.; Lei, Y.; Millar, D.S., “**Information-Theoretic Metrics in Coherent Optical Communications and their Applications**”, *European Conference on Optical Communication (ECOC)*, September 2018 ([TR2018-145](#))

Fujihashi, T.; Koike-Akino, T.; Watanabe, T.; Orlik, P.V., “**FreeCast: Graceful Free-Viewpoint Video Delivery**”, *IEEE Transactions on Multimedia*, DOI: 10.1109/TMM.2018.2870074, vol. 21, pp. 1000-1010, September 2018 ([TR2018-134](#))

Wichern, G.; Le Roux, J., “**Phase Reconstruction with Learned Time-Frequency Representations for Single-Channel Speech Separation**”, *International Workshop on Acoustic Signal Enhancement (IWAENC)*, DOI: 10.1109/IWAENC.2018.8521243, September 2018 ([TR2018-146](#))

Wang, J.; Cherian, A., “**Learning Discriminative Video Representations Using Adversarial Perturbations**”, *European Conference on Computer Vision (ECCV)*, September 2018 ([TR2018-139](#))

Sadamoto, K.; Tsujita, W.; Sawa, Y.; Wang, B.; Ma, R.; Wang, P.; Teo, K.H.; Orlik, P.V.; Kato, K.; Nakajima, M., “**Terahertz Polarimetric Sensing for Linear Encoder**”, *International Conference on Infrared, Millimeter and Terahertz Waves (IRMMW THz)*, DOI: 10.1109/IRMMW-THz.2018.8510391, September 2018 ([TR2018-142](#))

H. Fu, P. Wang, T. Koike-Akino, R. Ma, B. Wang, P. V. Orlik, W. Tsujita, K. Sadamoto, Y. Sawa, K. Kato and M. Nakajima, “**Terahertz Imaging of Multi-Level Pseudo-Random Reflectance**”, *International Conference on Infrared, Millimeter and Terahertz Waves (IRMMW-THz)*, DOI: 10.1109/irmmw-thz.2018.8510277, September 2018 ([TR2018-143](#))

- Kocanaogullari, A.; Ataer-Cansizoglu, E., “**Active Descriptor Learning for Feature Matching**”, *International Workshop on Compact and Efficient Feature Representation and Learning in Computer Vision*, September 2018 ([TR2018-132](#))
- Shou, Z.; Pan, J.; Chan, J.; Miyazawa, K.; Mansour, H.; Vetro, A.; Giro-i-Nieto, X.; Chang, S.-F., “**Online Detection of Action Start in Untrimmed, Streaming Videos**”, *European Conference on Computer Vision (ECCV)*, September 2018 ([TR2018-109](#))
- Wang, J.; Cherian, A., “**Discriminative Subspace Pooling for Action Recognition**”, *Workshop on Perceptual Organization in Computer Vision as part of the European Conference on Computer Vision (ECCV)*, September 2018 ([TR2018-141](#))
- Jones, M.J.; Broad, A.; Lee, T.-Y., “**Recurrent Multi-frame Single Shot Detector for Video Object Detection**”, *British Machine Vision Conference (BMVC)*, September 2018 ([TR2018-137](#))
- Wang, Z.-Q.; Le Roux, J.; Wang, D.; Hershey, J., “**End-to-End Speech Separation with Unfolded Iterative Phase Reconstruction**”, *Interspeech*, September 2018 ([TR2018-135](#))
- Watanabe, S.; Hori, T.; Karita, S.; Hayashi, T.; Nishitoba, J.; Unno, Y.; Enrique Yalta Soplin, N.; Heymann, J.; Wiesner, M.; Chen, N.; Renduchintala, A.; Ochiai, T., “**ESPnet: End-to-End Speech Processing Toolkit**”, *Interspeech*, September 2018 ([TR2018-136](#))
- Laftchiev, E.; Sun, X.; Dau, H.-A.; Nikovski, D.N., “**Anomaly Detection in Discrete Manufacturing Systems using Event Relationship Tables**”, *International Workshop on Principle of Diagnosis*, August 2018 ([TR2018-128](#))
- Berntorp, K.; Hoang, T.; Quirynen, R.; Di Cairano, S., “**Control Architecture Design for Autonomous Vehicles**”, *Conference on Control Technology and Applications (CCTA)*, DOI: 10.1109/CCTA.2018.8511371, pp. 404-411, August 2018 ([TR2018-125](#))
- Bortoff, S.A., “**Object-Oriented Modeling and Control of Delta Robots**”, *IEEE Conference on Control Technology and Applications*, August 2018 ([TR2018-126](#))
- Bortoff, S.A.; Burns, D.J.; Laughman, C.R.; Qiao, H.; Danielson, C.; Goldsmith, A.M.; Di Cairano, S., “**Power Optimizing Control of Multi-Zone Heat Pumps**”, *IEEE Conference on Control Technology and Applications*, August 2018 ([TR2018-127](#))
- Zhang, J.; Lee, T.-Y.; Feng, C.; Li, X.; Zhang, Z., “**Robust Attentional Pooling via Feature Selection**”, *IEEE International Conference on Pattern Recognition (ICPR)*, DOI: 10.1109/ICPR.2018.8545607, pp. 2038-2043, August 2018 ([TR2018-124](#))
- Laftchiev, E.; Liu, Y., “**Finding Multidimensional Patterns in Multidimensional Time Series**”, *SIGKDD Workshop on Mining and Learning From Time Series*, August 2018 ([TR2018-044](#))

- Kalabić, U.; Weiss, A.; Grover, P., “**Low-thrust GTO-to-GEO trajectory optimization and tracking**”, *Astrodynamics Specialist Conference*, August 2018 ([TR2018-117](#))
- Malyshev, A.; Quirynen, R.; Knyazev, A., “**Preconditioned Krylov iterations and condensing in interior point MPC method**”, *IFAC Conference on Nonlinear Model Predictive Control (NMPC)*, DOI: 10.1016/j.ifacol.2018.11.064, vol. 51, pp. 388-393, August 2018 ([TR2018-121](#))
- Baethge, T.; Kogel, M.; Di Cairano, S.; Findeisen, R., “**Contract-based Predictive Control for Modularity in Hierarchical Systems**”, *IFAC Conference on Nonlinear Model Predictive Control (NMPC)*, DOI: 10.1016/j.ifacol.2018.11.040, vol. 51, pp. 499-504, August 2018 ([TR2018-123](#))
- Quirynen, R.; Hespanhol, P., “**Quasi-Newton Jacobian and Hessian Updates for Pseudospectral based NMPC**”, *IFAC Conference on Nonlinear Model Predictive Control (NMPC)*, DOI: 10.1016/j.ifacol.2018.10.169, vol. 51, pp. 22-27, August 2018 ([TR2018-119](#))
- Quirynen, R.; Knyazev, A.; Di Cairano, S., “**Projected Preconditioning within a Block-Sparse Active-Set Method for MPC**”, *IFAC Conference on Nonlinear Model Predictive Control (NMPC)*, DOI: 10.1016/j.ifacol.2018.10.170, vol. 51, pp. 28-34, August 2018 ([TR2018-122](#))
- Malyshev, A.; Quirynen, R.; Knyazev, A., “**Preconditioning of conjugate gradient iterations in interior point MPC method**”, *IFAC Conference on Nonlinear Model Predictive Control (NMPC)*, DOI: 10.1016/j.ifacol.2018.11.065, vol. 51, pp. 394-399, August 2018 ([TR2018-120](#))
- Danielson, C., “**An Alternating Direction Method of Multipliers Algorithm for Symmetric MPC**”, *IFAC Conference on Nonlinear Model Predictive Control (NMPC)*, DOI: 10.1016/j.ifacol.2018.11.051, vol. 51, pp. 319-324, August 2018 ([TR2018-118](#))
- Dinis, D.; Ma, R.; Shinjo, S.; Yamanaka, K.; Teo, K.H.; Orlik, P.V.; Oliveira, A.; Vieira, J., “**A Real-time Architecture for Agile and FPGA-based Concurrent Triple-Band All-Digital RF Transmission**”, *IEEE Transaction on Microwave Theory and Techniques*, DOI: 10.1109/TMTT.2018.2860972, vol. 66, pp. 4955-4966, August 2018 ([TR2018-105](#))
- Elamvazhuthi, K.; Grover, P., “**Optimal Transport Over Nonlinear Systems via Infinitesimal Generators on Graphs**”, *Journal of Computational Dynamics*, DOI: 10.3934/jcd.2018001, vol. 5, pp. 1-32, August 2018 ([TR2018-115](#))
- Ma, R.; Benosman, M.; Manjunatha, K.; Komatsuszaki, Y.; Shinjo, S.; Teo, K.H.; Orlik, P.V., “**Machine-Learning Based Digital Doherty Power Amplifier**”, *IEEE International Symposium on Radio Frequency Integration Technology (RFIT)*, DOI: 10.1109/RFIT.2018.8524126, August 2018 ([TR2018-114](#))
- Qiao, H.; Laughman, C.R., “**Comparison of Approximate Momentum Equations in Dynamic Models of Vapor Compression Systems**”, *International Heat Transfer Conference*, August 2018 ([TR2018-131](#))

Shah, S.; Sun, H.; Nikovski, D.N.; Zhang, J., “**Consensus-based Synchronization of Microgrids at Multiple Points of Interconnection**”, *IEEE Power & Energy Society General Meeting*, DOI: 10.1109/PESGM.2018.8586167, August 2018 ([TR2018-112](#))

Wang, Y., “**Data-driven output feedback optimal control for a class of nonlinear systems via adaptive dynamic programming approach: Part I: Algorithms**”, *Chinese Control Conference (CCC)*, DOI: 10.23919/ChiCC.2018.8483373, pp. 2926-2932, July 2018 ([TR2018-107](#))

Liu, D.; Mansour, H.; Boufounos, P.T.; Kamilov, U., “**Robot Sensor Localization Based on Euclidean Distance Matrix**”, *IEEE International Geoscience and Remote Sensing Symposium (IGARSS)*, DOI: 10.1109/IGARSS.2018.8517324, pp. 7998-8001, July 2018 ([TR2018-106](#))

Seki, H.; Hori, T.; Watanabe, S.; Le Roux, J.; Hershey, J., “**A Purely End-to-end System for Multi-speaker Speech Recognition**”, *Annual Meeting of the Association for Computational Linguistics (ACL)*, pp. 2620-2630, July 2018 ([TR2018-104](#))

Elamvazhuthi, K.; Grover, P.; Berman, S., “**Optimal Transport over Deterministic Discrete-time Nonlinear Systems using Stochastic Feedback Laws**”, *IEEE Control Systems Letters*, DOI: 10.1109/LCSYS.2018.2855185, vol. 3, pp. 168-173, July 2018 ([TR2018-111](#))

Xiao, Y.; Taguchi, Y.; Kamat, V.R., “**Coupling Point Cloud Completion and Surface Connectivity Relation Inference for 3D Modeling of Indoor Building Environments**”, *Journal of Computing in Civil Engineering*, DOI: 10.1061/(ASCE)CP.1943-5487.0000776, vol. 32, July 12, 2018 ([TR2018-096](#))

Sanz, I.; Bernal, C.; Bono, A.; Pajovic, M.; Martinez, G., “**Gaussian Process Regression Applied to VRLA Battery Voltage Prediction in Photovoltaic Off-Grid Systems**”, *Jornada de Jovenes Investigadores*, July 11, 2018 ([TR2018-077](#))

Berntorp, K.; Weiss, A.; Di Cairano, S., “**GNSS Ambiguity Resolution by Adaptive Mixture Kalman Filter**”, *International Conference on Information Fusion (FUSION)*, DOI: 10.23919/ICIF.2018.8455617, July 2018 ([TR2018-103](#))

Pan, Y.; Farahmand, A.-M.; White, M.; Nabi, S.; Grover, P.; Nikovski, D.N., “**Reinforcement Learning with Function-Valued Action Spaces for Partial Differential Equation Control**”, *International Conference on Machine Learning (ICML)*, July 2018 ([TR2018-101](#))

Liu, H.-Y.; Liu, D.; Mansour, H.; Boufounos, P.T.; Waller, L.; Kamilov, U., “**SEAGLE: Sparsity-Driven Image Reconstruction under Multiple Scattering**”, *IEEE Transactions on Computational Imaging*, DOI: 10.1109/TCI.2017.2764461, vol. 4, pp. 73 - 86, July 9, 2018 ([TR2018-056](#))

Burns, D.J.; Bortoff, S.A.; Laughman, C.R.; Guay, M., “**Comparing Realtime Energy-Optimizing Controllers for Heat Pumps**”, *International Refrigeration and Air Conditioning Conference at Purdue*, July 2018 ([TR2018-100](#))

Qiao, H., “**Correction of Log Mean Temperature Difference Method and Effectiveness-NTU Relations for Two-phase Heat Transfer with Pressure Drop and Temperature Glide**”, *International Refrigeration and Air Conditioning Conference at Purdue*, July 2018 ([TR2018-129](#))

Qiao, H.; Laughman, C.R., “**Numerical Modeling of Fin-and-Tube Condenser with Wet-wall Desuperheating**”, *International Refrigeration and Air Conditioning Conference at Purdue*, July 2018 ([TR2018-130](#))

Laughman, C.R.; Bortoff, S.A.; Qiao, H., “**Integrated Control of Multi-Zone Buildings with Ventilation and VRF systems in Cooling Mode**”, *Purdue High-Performance Buildings Conference*, July 2018 ([TR2018-099](#))

Wang, P.; Fu, H.; Koike-Akino, T.; Orlik, P.V., “**Multi-Layer Terahertz Imaging of Non-Overlapping Contents**”, *IEEE Sensor Array and Multi-Channel Signal Processing Workshop (IEEE SAM)*, DOI: 10.1109/SAM.2018.8448438, pp. 652-656, July 2018 ([TR2018-098](#))

Di Cairano, S.; Goldsmith, A.M.; Kalabić, U.; Bortoff, S.A., “**Cascaded Reference Governor-MPC for Motion Control of Two-Stage Manufacturing Machine**”, *IEEE Transactions on Control Systems Technology*, DOI: 10.1109/TCST.2018.2847627, July 2018 ([TR2018-083](#))

Liu, J.; Guo, J.; Orlik, P.V.; Shibata, M.; Nakahara, D.; Mii, S.; Takac, M., “**Anomaly Detection in Manufacturing Systems Using Structured Neural Networks**”, *IEEE World Congress on Intelligent Control and Automation*, DOI: 10.1109/WCICA.2018.8630692, pp. 175-180, July 2018 ([TR2018-097](#))

Berntorp, K., “**Comparison of Gain Function Approximation Methods in the Feedback Particle Filter**”, *International Conference on Information Fusion (FUSION)*, DOI: 10.1109/WCICA.2018.8630692, pp. 175-180, July 2018 ([TR2018-102](#))

Koike-Akino, T.; Wang, Y.; Millar, D.S.; Kojima, K.; Parsons, K., “**Polar Coding for Multilevel Shaped Constellations**”, *Signal Processing in Photonic Communications (SPPCom)*, DOI: 10.1364/SPPCOM.2018.SpW1G.1, July 2018 ([TR2018-046](#))

Koike-Akino, T.; Millar, D.S.; Parsons, K.; Kojima, K., “**Fiber Nonlinearity Equalization with Multi-Label Deep Learning Scalable to High-Order DP-QAM**”, *Signal Processing in Photonic Communications (SPPCom)*, DOI: 10.1364/SPPCOM.2018.SpM4G.1, July 2018 ([TR2018-047](#))

Koike-Akino, T.; Millar, D.S.; Parsons, K.; Kojima, K., “**Evolutionary Design of Pulse-Shaping FIR Filter to Mitigate Fiber Nonlinearity**”, *Signal Processing in Photonic Communications (SPPCom)*, DOI: 10.1364/SPPCOM.2018.SpM4G.4, July 2018 ([TR2018-045](#))

Liu, H.; Yeoh, P.L.; Kim, K.J.; Orlik, P.V.; Poor, H.V., “**Secrecy Performance of Finite-Sized In-Band Selective Relaying Systems with Unreliable Backhaul and Cooperative Eavesdroppers**”, *IEEE Journal on Selected Areas in Communications*, DOI: 10.1109/JSAC.2018.2824418, vol. 36, pp. 1499-1516, July 2018 ([TR2018-110](#))

You, J.; Wu, W.; Wang, Y., “**An Adaptive Luenberger Observer for Speed-Sensorless Estimation of Induction Machines**”, *American Control Conference (ACC)*, DOI: 10.23919/ACC.2018.8431006, pp. 307-312, June 2018 ([TR2018-090](#))

Berntorp, K.; Di Cairano, S., “**Offset and Noise Estimation of Automotive-Grade Sensors Using Adaptive Particle Filtering**”, *American Control Conference (ACC)*, DOI: 10.23919/ACC.2018.8430835, pp. 4745-4750, June 2018 ([TR2018-092](#))

Caverly, R.; Di Cairano, S.; Weiss, A., “**Split-Horizon MPC for Coupled Station Keeping, Attitude Control, and Momentum Management of GEO Satellites using Electric Propulsion**”, *American Control Conference (ACC)*, DOI: 10.23919/ACC.2018.8431329, pp. 652-657, June 2018 ([TR2018-093](#))

Berntorp, K.; Di Cairano, S., “**Approximate Noise-Adaptive Filtering Using Student-t Distributions**”, *American Control Conference (ACC)*, DOI: 10.23919/ACC.2018.8430902, pp. 2745-2750, June 2018 ([TR2018-088](#))

Poveda, J.; Benosman, M.; Teel, A.; Sanfelice, R.G., “**A Hybrid Adaptive Feedback Law for Robust Obstacle Avoidance and Coordination in Multiple Vehicle Systems**”, *American Control Conference (ACC)*, DOI: 10.23919/ACC.2018.8431064, pp. 616-621, June 2018 ([TR2018-094](#))

Ahn, H.; Berntorp, K.; Di Cairano, S., “**Reachability-based Decision Making for City Driving**”, *American Control Conference (ACC)*, DOI: 10.23919/ACC.2018.8431819, pp. 3203-3208, June 2018 ([TR2018-091](#))

Di Cairano, S.; Kolmanovsky, I.V., “**Real-time optimization and model predictive control for aerospace and automotive applications**”, *American Control Conference (ACC)*, DOI: 10.23919/ACC.2018.8431819, pp. 2392-2409, June 2018 ([TR2018-086](#))

Quirynen, R.; Berntorp, K.; Di Cairano, S., “**Embedded Optimization Algorithms for Steering in Autonomous Vehicles based on Nonlinear Model Predictive Control**”, *American Control Conference (ACC)*, DOI: 10.23919/ACC.2018.8431260, pp. 3251-3256, June 2018 ([TR2018-089](#))

Greiff, M.; Berntorp, K., “**Evaluation of the Discrete Time Feedback Particle Filter for IMU-Driven Systems Configured on SE(2)**”, *American Control Conference (ACC)*, DOI: 10.23919/ACC.2018.8431134, pp. 5683-5689, June 2018 ([TR2018-087](#))

Raghunathan, A.U.; Bergman, D.; Hooker, J.; Serra, T.; Kobori, S., “**The Integrated Last-Mile Transportation Problem (ILMTP)**”, *International Conference on Automated Planning and Scheduling (ICAPS)*, June 2018 ([TR2018-084](#))

Grover, P.; Bakshi, K.; Theodorou, E., “**A mean-field game model for homogenous flocking**”, *Chaos: An Interdisciplinary Journal of Nonlinear Science*, DOI: 10.1063/1.5036663, vol. 28, June 2018 ([TR2018-032](#))

Nowara, E.; Marks, T.K.; Mansour, H.; Nakamura, Y.; Veeraraghavan, A., “**SparsePPG: Towards Driver Monitoring Using Camera-Based Vital Signs Estimation in Near-Infrared**”, *CVPR workshop: CVPM 2018. IEEE Conference on Computer Vision and Pattern Recognition (CVPR) Workshop on Computer Vision for Physiological Measurement (CVPM)*, pp. 1272-1281, June 2018 ([TR2018-067](#))

Zhang, Z.; Wu, Y.; Wang, G., “**BPGGrad: Towards Global Optimality in Deep Learning via Branch and Pruning**”, *IEEE Conference on Computer Vision and Pattern Recognition (CVPR)*, pp. 3301-3309, June 2018 ([TR2018-068](#))

Yang, Y.; Feng, C.; Shen, Y.; Tian, D., “**FoldingNet: Point Cloud Auto-encoder via Deep Grid Deformation**”, *IEEE Conference on Computer Vision and Pattern Recognition (CVPR)*, DOI: 10.1109/CVPR.2018.00029, June 2018 ([TR2018-042](#))

Shen, Y.; Feng, C.; Yang, Y.; Tian, D., “**Mining Point Cloud Local Structures by Kernel Correlation and Graph Pooling**”, *IEEE Conference on Computer Vision and Pattern Recognition (CVPR)*, June 2018 ([TR2018-041](#))

Kalabić, U.; Di Cairano, S., “**Inner-Loop Reference Governor Design with an Application to Human-in-the-Loop Control**”, *European Control Conference (ECC)*, DOI: 10.23919/ECC.2018.8550423, pp. 1021-1026, June 2018 ([TR2018-079](#))

Quirynen, R.; Hespanhol, P., “**A Real-Time Iteration Scheme with Quasi-Newton Jacobian Updates for Nonlinear Model Predictive Control**”, *European Control Conference (ECC)*, DOI: 10.23919/ECC.2018.8550541, pp. 1517-1522, June 2018 ([TR2018-082](#))

Caverly, R.; Di Cairano, S.; Weiss, A., “**On-Off Quantization of an MPC Policy for Coupled Station Keeping, Attitude Control, and Momentum Management of GEO Satellites**”, *European Control Conference (ECC)*, DOI: 10.23919/ECC.2018.8550336, June 2018 ([TR2018-078](#))

Malyshev, A.; Quirynen, R.; Knyazev, A.; Di Cairano, S., “**A regularized Newton solver for linear model predictive control**”, *European Control Conference (ECC)*, DOI: 10.23919/ECC.2018.8550438, pp. 1393-1398, June 2018 ([TR2018-080](#))

Quirynen, R.; Knyazev, A.; Di Cairano, S., “**Block Structured Preconditioning within an Active-Set Method for Real-Time Optimal Control**”, *European Control Conference (ECC)*, DOI: 10.23919/ECC.2018.8550316, pp. 1154-1159, June 2018 ([TR2018-081](#))

Komatsuzaki, Y.; Lanfranco, S.; Komlonen, T.; Piirainen, O.; Tanskanen, J.; Sakata, S.; Ma, R.; Shinjo, S.; Yamanaka, K.; Asbeck, P., “**A High Efficiency 3.6-4.0 GHz Envelope-Tracking Power Amplifier Using GaN Soft-Switching Buck-Converter**”, *IEEE International Microwave Symposium (IMS)*, DOI: 10.1109/MWSYM.2018.8439225, pp. 465-468, June 2018 ([TR2018-073](#))

Dinis, D.; Ma, R.; Teo, K.H.; Orlik, P.V.; Oliveira, A.; Vieira, J., “**An FPGA-based Multi-level All-Digital Transmitter with 1.25 GHz of Bandwidth**”, *IEEE International Microwave Symposium (IMS)*, DOI: 10.1109/MWSYM.2018.8439490, pp. 659-662, June 2018 ([TR2018-075](#))

Pajovic, M., “**Misspecified Bayesian Cramer-Rao Bound for Sparse Bayesian Learning**”, *IEEE Statistical Signal Processing Workshop (SSP)*, DOI: 10.1109/SSP.2018.8450780, pp. 263-267, June ([TR2018-076](#))

Liu, F.; H.Z.; Li, J.; Wang, P.; Orlik, P.V., “**Massive MIMO Channel Estimation using Signed Measurements with Antenna-Varying Thresholds**”, *IEEE Statistical Signal Processing Workshop (SSP)*, DOI: 10.1109/SSP.2018.8450804, pp. 188-192, June 2018 ([TR2018-074](#))

Deshmukh, A.; Laftchiev, E., “**Semi-Supervised Transfer Learning Using Marginal Predictors**”, *IEEE Data Science Workshop*, DOI: 10.1109/DSW.2018.8439908, pp. 160-164, June 6, 2018 ([TR2018-040](#))

Wittenburg, K.B.; Lee, T.-Y., “**Equal-Height Treemaps for Multivariate Data**”, *International Working Conference on Advanced Visual Interfaces (AVI)*, DOI: 10.1145/3206505.3206591, May 2018 ([TR2018-063](#))

Tanovic, O.; Ma, R., “**Compact Analytical Description of Digital Radio-Frequency Pulse-Width Modulated Signals**”, *IEEE International Symposium on Circuits & Systems (ISCAS), 2018*, DOI: 10.1109/ISCAS.2018.8351725, May 2018 ([TR2018-065](#))

Keerthisinghe, C.; Sun, H.; Takaguchi, Y.; Nikovski, D.N.; Hashimoto, H., “**Machine Learning Based State-Space Approximate Dynamic Programming Approach for Energy and Reserve Management of Power Plants**”, *IEEE PES Innovative Smart Grid Technologies Asia (ISGT Asia)*, DOI: 10.1109/ISGT-Asia.2018.8467807, pp. 669-674, May 2018 ([TR2018-064](#))

Pajovic, M.; Orlik, P.V., “**Reduced-Dimension Symbol Detection in Random Access Channel**”, *IEEE International Conference on Communications (ICC)*, DOI: 10.1109/ICC.2018.8422126, May 2018 ([TR2018-060](#))

Kim, K.J.; Liu, H.; Renzo, M.D.; Orlik, P.V.; Poor, H.V., “**Secrecy Performance Analysis of Distributed CDD based Cooperative Systems with Jamming**”, *IEEE International Conference on Communications (ICC)*, DOI: 10.1109/ICC.2018.8422679, May 2018 ([TR2018-053](#))

Koike-Akino, T.; Cao, C.; Wang, Y., “**Turbo Product Codes with Irregular Polar Coding for High-Throughput Parallel Decoding in Wireless OFDM Transmission**”, *IEEE International Conference on Communications (ICC)*, DOI: 10.1109/ICC.2018.8422466, May 2018 ([TR2018-038](#))

Kim, K.J.; Renzo, M.D.; Liu, H.; Orlik, P.V.; Poor, H.V., “**Diversity Gain Analysis of Distributed CDD Systems in Non-identical Frequency Selective Fading**”, *IEEE International Conference on Communications (ICC)*, DOI: 10.1109/ICC.2018.8422918, May 2018 ([TR2018-061](#))

Fujihashi, T.; Koike-Akino, T.; Watanabe, T.; Orlik, P.V., “**Nonlinear Equalization with Deep Learning for Multi-Purpose Visual MIMO Communications**”, *IEEE International Conference on Communications (ICC)*, DOI: 10.1109/ICC.2018.8422544, May 2018 ([TR2018-039](#))

Laughman, C.R.; Bortoff, S.A.; Qiao, H., “**Modeling and Coordinated Control of an Air-Source Heat Pump and Hydronic Radiant Heating System**”, *Japanese Modelica Conference*, May 2018 ([TR2018-059](#))

Dinis, D.; Ma, R.; Teo, K.H.; Orlik, P.V.; Oliveira, A.; Vieira, J., “**Towards Analog Filter-Free All-Digital Transmitters through Hybrid Estimation and Cancellation of Delta-Sigma M's Quantization Noise**”, *International Microwave and Radar Conference*, May 2018 ([TR2018-057](#))

Kojima, K.; Parsons, K.; Koike-Akino, T.; Millar, D.S., “**Mapping options of 4D constant modulus format for multi-subcarrier modulation**”, *Conference on Lasers and Electro-Optics (CLEO)*, May 2018 ([TR2018-052](#))

Wang, P.; Millar, D.S.; Parsons, K.; Orlik, P.V., “**Nonlinearity Correction for Range Estimation in FMCW Millimeter-Wave Automotive Radar**”, *IEEE International Wireless Symposium (IWS)*, DOI: 10.1109/IEEE-IWS.2018.8400806, May 2018 ([TR2018-054](#))

Weiss, A.; Kalabić, U.; Di Cairano, S., “**Station keeping and momentum management of low-thrust satellites using MPC**”, *Aerospace Science and Technology*, DOI: 10.1016/j.ast.2018.02.014, vol. 76, pp. 229-241, May 2018 ([TR2018-048](#))

Brand, M.E., “**Tri-tone freeforms**”, *Laser Display and Lighting Conference*, April 2018 ([TR2018-043](#))

Wang, Z.-Q.; Le Roux, J.; Hershey, J.R., “**Multi-Channel Deep Clustering: Discriminative Spectral and Spatial Embeddings for Speaker-Independent Speech Separation**”, *IEEE International Conference on Acoustics, Speech, and Signal Processing (ICASSP)*, DOI: 10.1109/ICASSP.2018.8461639, pp. 1-5, April 2018 ([TR2018-007](#))

Wang, Z.-Q.; Le Roux, J.; Hershey, J.R., “**Alternative Objective Functions for Deep Clustering**”, *IEEE International Conference on Acoustics, Speech, and Signal Processing (ICASSP)*, DOI: 10.1109/ICASSP.2018.8462507, pp. 686-690, April 2018 ([TR2018-005](#))

Settle, S.; Le Roux, J.; Hori, T.; Watanabe, S.; Hershey, J.R., “**End-to-End Multi-Speaker Speech Recognition**”, *IEEE International Conference on Acoustics, Speech, and Signal Processing (ICASSP)*, DOI: 10.1109/ICASSP.2018.8461893, pp. 4819-4823, April 2018 ([TR2018-001](#))

Wen, B.; Kamilov, U.; Liu, D.; Mansour, H.; Boufounos, P.T., “**DeepCASD: An End-to-End Approach for Multi-Spectral Image Super-Resolution**”, *IEEE International Conference on Acoustics, Speech, and Signal Processing (ICASSP)*, DOI: 10.1109/ICASSP.2018.8461795, pp. 6503-6507, April 2018 ([TR2018-009](#))

Ochiai, T.; Watanabe, S.; Katagiri, S.; Hori, T.; Hershey, J.R., “**Speaker Adaptation for Multichannel End-to-End Speech Recognition**”, *IEEE International Conference on Acoustics, Speech, and Signal Processing (ICASSP)*, DOI: 10.1109/ICASSP.2018.8462161, pp. 6707-6711, April 2018 ([TR2018-006](#))

Mansour, H.; Kamilov, U.S.; Liu, D.; Boufounos, P.T., “**Radar Autofocus Using Sparse Blind Deconvolution**”, *IEEE International Conference on Acoustics, Speech, and Signal Processing (ICASSP)*, DOI: 10.1109/ICASSP.2018.8462402, pp. 1623-1627, April 2018 ([TR2018-003](#))

Seki, H.; Watanabe, S.; Hori, T.; Le Roux, J.; Hershey, J.R., “**An End-to-End Language-Tracking Speech Recognizer for Mixed-Language Speech**”, *IEEE International Conference on Acoustics, Speech, and Signal Processing (ICASSP)*, DOI: 10.1109/ICASSP.2018.8462180, pp. 4919-4923, April 2018 ([TR2018-002](#))

Fu, H.; Wang, P.; Koike-Akino, T.; Orlik, P.V.; Chi, Y., “**Terahertz Imaging of Binary Reflectance with Variational Bayesian Inference**”, *IEEE International Conference on Acoustics, Speech, and Signal Processing (ICASSP)*, DOI: 10.1109/ICASSP.2018.8461987, pp. 3394-3398, April 2018 ([TR2018-004](#))

Peng, Z.; Kim, K.J.; Wang, P.; Ma, R.; Kihira, K.; Fukasawa, T.; Li, C.; Wang, B., “**Code-Division Multiplexing based Hardware Reduction for a Digital Beamforming Transmitter Array**”, *European Conference on Antennas and Propagation (EuCAP)*, April 2018 ([TR2018-049](#))

Hongtao, Q.; Aute, V.; Radermacher, R., “**Modeling of transient characteristics of an air source heat pump with vapor injection during reverse-cycle defrosting**”, *Applied Energy*, DOI: 10.1016/j.ijrefrig.2017.12.017, vol. 88, pp. 24-34, April 2018 ([TR2018-066](#))

Research

The body and soul of any research lab is its portfolio of research projects. The main body of this annual report consists of descriptions of research recently done at MERL. The reports are grouped into seven topic areas corresponding to MERL's seven research groups.

Computer Vision – Teaching computers and robots to see, understand and interact with the world. Generating and processing 2D and 3D image data from across space and time using machine learning to extract meaning and build representations of scenes, objects and events through the development of algorithms to perform detection, classification, recognition, and 3D reconstruction. Development of simulators to enable training of machine learning for vision and robot system, and in data-poor industrial applications.

Data Analytics – Learning and optimization algorithms that can be applied to electrical power systems, various transportation systems (trains, elevators, cars), heating, ventilation, and air conditioning (HVAC) systems and solutions, and factory automation. The application of these algorithms minimizes costs, increases reliability, improves energy efficiency, and reduces environmental impact of products.

Speech & Audio – Machine learning for estimation and inference problems in speech and audio processing, including end-to-end speech recognition and enhancement, acoustic modeling and analysis, statistical dialog systems, as well as natural language understanding and adaptive multimodal interfaces.

Signal Processing – Acquisition, representation, and processing of signals with an emphasis on wireless/optical communications and associated devices, computational sensing, radar processing and statistical inference. Application areas include: terrestrial and trans-oceanic optical networks, train and automotive connectivity and electronics, energy storage systems, RF power amplifiers, RF sensing systems for security, infrastructure and building monitoring.

Control & Dynamical Systems – If it moves, we control it: Advanced control algorithms, model predictive control, estimation, nonlinear dynamical systems, system-level dynamic modeling and analysis, mechatronic co-design, thermo-fluid system dynamics, with applications to automotive mechatronics, factory automation, elevators, space systems, motors, trains, and HVAC.

Multi-Physical Systems & Devices – Research on multi-physical modeling & simulations as a basis for producing model-based design for devices, systems and controls to achieve optimized performance with high efficiency. Target applications include HVAC systems, factory automation, robotics, electrical motors, power amplifier devices, superconductors, and nano-particles for future magnetic particle imaging.

Computer Vision

The research in the Computer Vision group at MERL covers all aspects of extracting information from images, videos and point clouds as well as robotic active 3D reconstruction and learning. A major new tool for this is deep neural network learning, often erroneously called artificial intelligence, which has had a transformative impact on the field. Deep learning pervades our projects enabling them to achieve superhuman results in many common computer vision tasks such as object detection and classification.

Several of our current projects involve 3D analysis based on 2D images. For example, we have developed algorithms for estimation of object pose so that a robot arm can grasp an object from a cluttered workspace. In another project, we build a 3D model from 2D images that can be used for automatic parking. In all these cases, the algorithms we have developed must be very fast and accurate. We have also developed algorithms that operate directly on 3D data for reconstruction, detection, and recognition. We process point clouds of data from laser scans of objects and scenes to extract data for map generation, vehicle localization, and object classification.

For many years, MERL has applied machine-learning methods to imaging problems of detection, classification, segmentation and understanding. A decade ago, the Viola-Jones algorithm for face detection was a good example. More recently we have been applying deep learning for semantic scene labeling and people detection/re-identification. We have also developed physics-based simulators of 3D puzzles and use reinforcement learning to train a real robot to solve the puzzle. We have blended our research in 3D and machine learning to enable learning of the most effective features to use in 3D detection and estimation tasks.

Recent Research

Learning Tasks Involving Complex Dynamics	44
Sem-GAN: Semantically-Consistent Image-to-Image Translation	44
Super-resolution of Very Low-Resolution Faces from Videos	45
Recurrent Multi-Frame Single Shot Detector for Video Object Detection.....	45
Robust Attentional Pooling via Feature Selection.....	46
FoldingNet: Interpretable Unsupervised Learning on 3D Point Clouds.....	46
Mining Point Cloud Local Structures by Kernel Correlation and Graph Pooling.....	47
SparsePPG: Towards Driver Monitoring Using Camera-Based Vital Signs Estimation ...	47
Learning Tasks Involving Complex Dynamics	48
Localization-Aware Active Learning for Object Detection.....	48
Discriminative Subspace Pooling for Action Recognition	49
BPGGrad: Towards Global Optimality in Deep Learning via Branch and Pruning	49
3D Object Discovery and Modeling Using Single RGB-D Images Containing ...	50
Joint 3D Reconstruction of a Static Scene and Moving Objects.....	50

Learning Tasks Involving Complex Dynamics

Citation: Van Baar, J.; Jha, D.; Romeres, D.; Sullivan, A.; Nikovski, D., "Learning Tasks in a Complex Circular Maze Environment", *Modeling the Physical World: Perception, Learning, and Control, NIPS Workshop*, December 2018

Contacts: Jeroen van Baar, Devesh Jha, Diego Romeres, Alan Sullivan, Daniel Nikovski

Although many methods have been presented for learning by modeling the physical world, most tasks involve simple dynamics, or solutions are only demonstrated in simulation. In this paper we present the challenging task of learning to solve a marble maze game on a real system. We explain what makes this problem so difficult and briefly discuss two methods we recently proposed, including some results. We conclude this paper with a discussion of several possible research directions for such challenging problems.



Sem-GAN: Semantically-Consistent Image-to-Image Translation

Citation: Cherian, A.; Sullivan, A., " Sem-GAN: Semantically-Consistent Image-to-Image Translation", *IEEE Winter Conference on Applications of Computer Vision (WACV)*, January, 2019.

Contacts: Anoop Cherian, Alan Sullivan

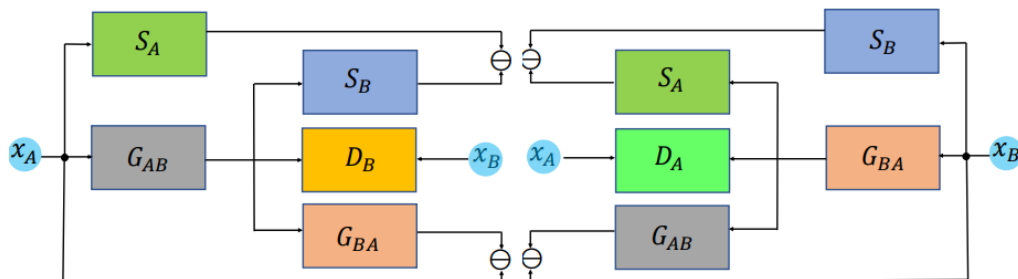

Unpaired image-to-image translation is the problem of mapping an image in the source domain to one in the target domain, without requiring corresponding image pairs. To ensure the translated images are realistically plausible, recent works, such as Cycle-GAN, demands this mapping be invertible. While, this requirement demonstrates promising results when the domains are uni-modal, its performance is unpredictable in a multi-modal scenario such as in an image segmentation task. This is because, invertibility does not necessarily enforce semantic correctness. To this end, we present a semantically-consistent GAN framework, dubbed Sem-GAN, in which the semantics are defined by the class identities of image segments in the source domain as produced by a semantic segmentation algorithm. Our proposed framework includes consistency constraints on the translation task that, together with the GAN loss and the cycle-constraints, enforces that the images when translated will inherit the appearances of the target domain, while (approximately) maintaining their identities from the source domain.

Super-resolution of Very Low-Resolution Faces from Videos

Citation: Ataer-Cansizoglu E., Jones, M., “Super-resolution of Very Low-Resolution Faces from Videos”, *IEEE Winter Conference on Applications of Computer Vision (WACV)*, DOI: 10.1109/WACV.2016.7477698, pp. 1-9, March 2016

Contacts: Mike Jones

Faces appear in low-resolution video sequences in various domains such as surveillance. The intensity information coming from other frames of the sequence can be used to super-resolve a face image. We present a method to super-resolve a face image using consecutive frames of a face in the same sequence. Our method is

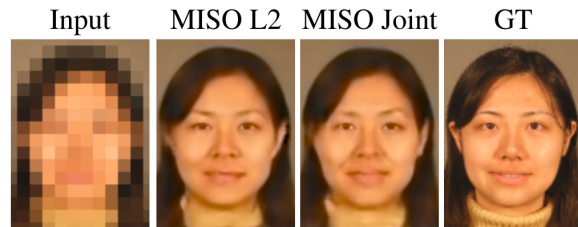

based on a novel multi-input-single-output framework with a Siamese deep network architecture that fuses multiple frames into a single face image. Contrary to existing work on video super-resolution, it is model free and does not depend on facial landmark detection that might be difficult to handle for very low-resolution faces. Experiments show that the use of multiple frames as input improves the performance compared to single-input-single-output systems.

Recurrent Multi-Frame Single Shot Detector for Video Object Detection

Citation: Jones, M.; Broad, A.; Lee, T.Y., “Recurrent Multi-Frame Single Shot Detector for Video Object Detection”, *British Machine Vision Conference (BMVC)*, September 2018

Contacts: Mike Jones, Teng-Yok Lee

Deep convolutional neural networks (CNNs) have recently proven extremely capable of performing object detection in single-frame images. In this work, we extend a class of CNNs designed for static image object detection to multi-frame video object detection. Our Multi-frame Single Shot Detector (Mf-

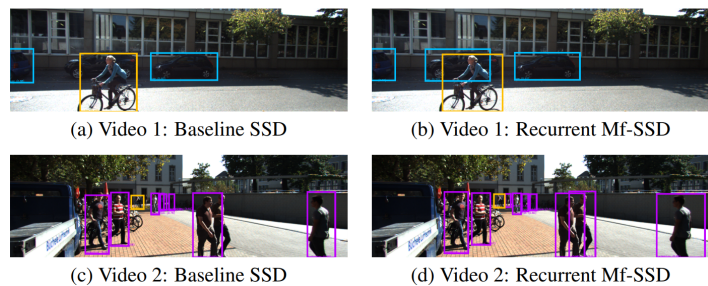

SSD) augments the Single Shot Detector (SSD) meta-architecture to incorporate temporal information from video data. By adding a convolutional recurrent layer to an SSD architecture our model fuses features across multiple frames and takes advantage of the additional spatial and temporal information available in video data to improve the overall accuracy of the object detector. Our solution uses a fully convolutional network architecture to retain the impressive speed of single-frame SSDs. Our approach improves upon a state-of-the-art SSD model by 2.7 percentage points in mean average precision (mAP) on the challenging KITTI dataset and by 5.1 percentage points on the most difficult set of KITTI objects. Additional experiments demonstrate that our Mf-SSD can incorporate a wide range of underlying network architectures and that in each case, the multi-frame model consistently improves upon single-frame baselines.

Robust Attentional Pooling via Feature Selection

Citation: Zhang, J.; Lee, T.-Y.; Feng, C.; Li, X.; Zhang, Z., "Robust Attentional Pooling via Feature Selection", *IEEE International Conference on Pattern Recognition (ICPR)*, DOI: 10.1109/ICPR.2018.8545607, pp. 2038-2043, August 2018.
 Contacts: Teng-yok Lee, Ziming Zhang

In this paper we propose a novel framework for constructing deep attentional models which can learn feature weights as attention in data for recognition purpose. Our framework consists of two modules sequentially, namely, (1) feature adaptation that maps original data into another feature space, and (2) attention learning that learns weights for feature combination. Each modular is represented by a neural network, and both are learned simultaneously with the classifier. We demonstrate our deep attentional models based on visual object recognition in 3D point clouds. We show that our models can learn reasonable spatial attentions as well as improving recognition accuracy.

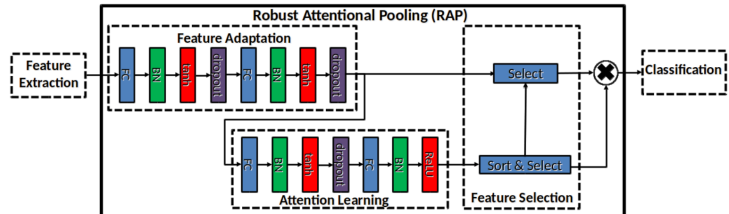

FoldingNet: Interpretable Unsupervised Learning on 3D Point Clouds

Citation: Yang, Y., Feng, C., Shen, Y., Tian, D., "FoldingNet: Interpretable Unsupervised Learning on 3D Point Clouds," *arXiv*, December 2017
 Contacts: Chen Feng, Dong Tian

Recent deep networks that directly handle points in a point set, e.g., PointNet, have been state-of-the-art for supervised semantic learning tasks on point clouds such as classification and segmentation. In this work, a novel end-to-end deep auto-encoder is proposed

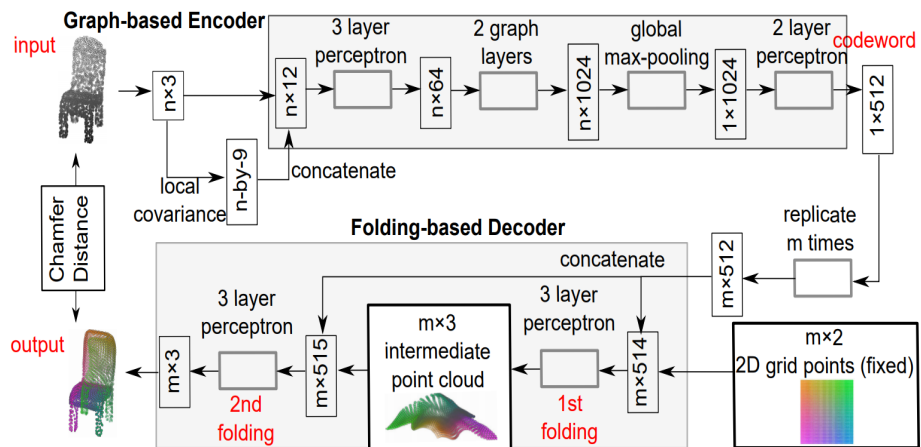

to address unsupervised learning challenges on point clouds. On the encoder side, a graph-based enhancement is enforced to promote local structures on top of PointNet. Then, a novel folding-based approach is proposed in the decoder, which folds a 2D grid onto the underlying 3D object surface of a point cloud. The proposed decoder only uses about 7% as many parameters as a decoder with fully-connected neural networks, yet leads to a more discriminative representation that achieves higher linear SVM classification accuracy than the benchmark.

Mining Point Cloud Local Structures by Kernel Correlation and Graph Pooling

Citation: Shen, Y.; Feng, C.; Yang, Y.; Tian, D., “Mining Point Cloud Local Structures by Kernel Correlation and Graph Pooling”, *IEEE Conference on Computer Vision and Pattern Recognition (CVPR)*, June 2018

Contacts: Alan Sullivan

Unlike on images, semantic learning on 3D point clouds by a deep network is challenging due to the unordered data structure. Among existing works, PointNet has achieved promising results by directly learning on point sets. However, it does not take full advantage of a point's local structure that captures fine-grained properties, which turns out to be helpful towards better semantic learning. We present two new operations to improve PointNet by more efficient exploitation of local structures. Experiments show that our network is able to capture local information robustly and achieve better performance on major data-sets.

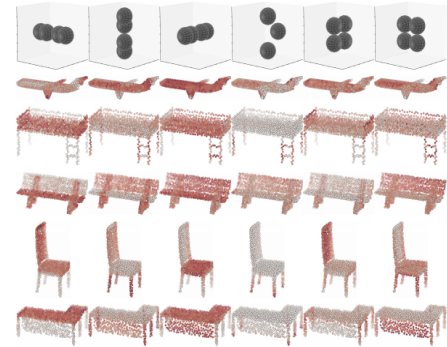

SparsePPG: Towards Driver Monitoring Using Camera-Based Vital Signs Estimation in Near-Infrared

Citation: Nowara, E.; Marks, T.K.; Mansour, H.; Nakamura, Y.; Veeraraghavan, A., “SparsePPG: Towards Driver Monitoring Using Camera-Based Vital Signs Estimation in Near-Infrared”, *CVPR workshop: CVPM 2018. IEEE Conference on Computer Vision and Pattern Recognition (CVPR) Workshop on Computer Vision for Physiological Measurement (CVPM)*, pp. 1272-1281, June 2018.

Contacts: Tim K. Marks, Hassan Mansour

Camera-based measurement of the heartbeat signal from minute changes in the appearance of a person's skin is known as remote photoplethysmography (rPPG). Methods for rPPG have improved considerably in recent years, making possible its integration into applications such as telemedicine. Driver monitoring using in-car cameras is another potential application of this emerging technology. There are several challenges unique to the driver monitoring context that must be overcome. First, there are drastic illumination changes on the driver's face, both during the day (as sun filters in and out of overhead trees, etc.) and at night (from streetlamps and oncoming headlights). Second, the amount of motion during driving is significant. Third, low signal-to-noise ratio (SNR) and false peaks due to motion have the potential to confound the PPG signal. To address these challenges, we develop a novel PPG signal tracking and denoising algorithm (sparsePPG) based on Robust Principal Components Analysis and sparse frequency spectrum estimation. We demonstrate that our new method performs as well as or better than current state-of-the-art rPPG algorithms.

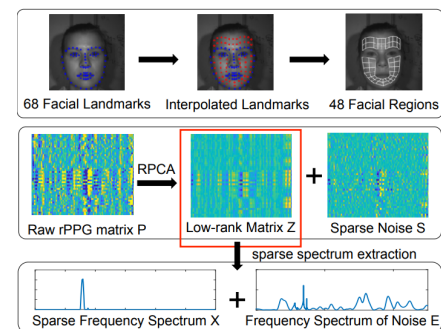

Learning Tasks Involving Complex Dynamics

Citation: Brand, M.E., “Tri-tone freeforms”, *Laser Display and Lighting Conference*, April 2018

Contacts: Matt Brand

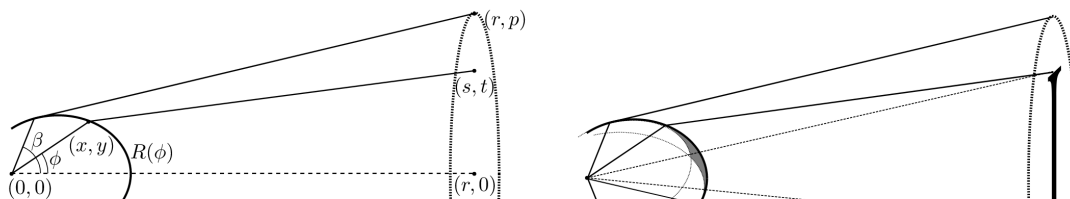

Figure 1. Summary of this paper. LEFT: Refractor surface $R(\phi)$ converts a Lambertian point source at origin to a uniformly irradiated disk of radius p at distance r . RIGHT: Sinking parts of the surface produces black (unlit) regions whose rays are redirected to the figure/ground boundary, producing a tri-tone graphic.

We find a closed-form solution for the shape of the refractive surface that uniformly irradiates a disk from a Lambertian point light source, then algebraically tailor this surface to project tri-tone graphics.

Localization-Aware Active Learning for Object Detection

Citation: Kao, C.-C.; Lee, T.-Y.; Sen, P.; Liu, M.-Y., “Localization-Aware Active Learning for Object Detection”, *Asian Conference on Computer Vision (ACCV)*, December 2018

Contacts: Teng-Yok Lee

Active learning---a class of algorithms that iteratively search for the most informative samples to include in a training dataset---has been shown to be effective at annotating data for image classification. However, the use of active learning for object detection is still largely unexplored as determining informativeness of an object-location hypothesis is more difficult. In this paper, we address this issue and present two metrics for measuring the informativeness of an object hypothesis, which allow us to leverage active learning to reduce the amount of annotated data needed to achieve a target object detection performance. Our first metric measures “localization tightness” of an object hypothesis, which is based on the overlapping ratio between the region proposal and the final prediction. Our second metric measures “localization stability” of an object hypothesis, which is based on the variation of predicted object locations when input images are corrupted by noise. Our experimental results show that by augmenting a conventional active-learning algorithm designed for classification with the proposed metrics, the amount of labeled training data required can be reduced up to 25%. Moreover, on PASCAL 2007 and 2012 datasets our localization-stability method has an average relative improvement of 96.5% and 81.9% over the classification only baseline method.

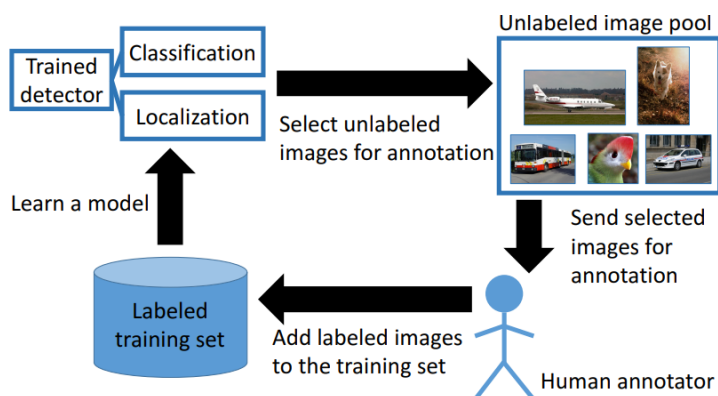

Discriminative Subspace Pooling for Action Recognition

Citation: Wang, J.; Cherian, A., “Discriminative Subspace Pooling for Action Recognition”, *Workshop on Perceptual Organization in Computer Vision as part of the European Conference on Computer Vision (ECCV)*, September 2018

Contacts: Anoop Cherian

Adversarial perturbations are noise-like patterns that can subtly change the data, while failing an otherwise accurate classifier. In this paper, we propose to use such perturbations for improving the robustness of video representations. To this end, given a well-trained deep model for per-frame video recognition, we first generate adversarial noise adapted to this model. Using the original data features from the full video sequence and their perturbed counterparts, as two separate bags, we develop a binary classification problem that learns a set of discriminative hyperplanes – as a subspace – that will separate the two bags from each other. This subspace is then used as a descriptor for the video, dubbed discriminative subspace pooling. As the perturbed features belong to data classes that are likely to be confused with the original features, the discriminative subspace will characterize parts of the feature space that are more representative of the original data, and thus may provide robust video representations. To learn such descriptors, we formulate a subspace learning objective on the Stiefel manifold and resort to Riemannian optimization methods for solving it efficiently. We provide experiments on several video datasets and demonstrate state-of-the-art results.

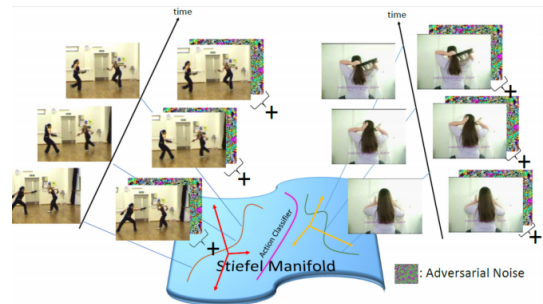

As the perturbed features belong to data classes that are likely to be confused with the original features, the discriminative subspace will characterize parts of the feature space that are more representative of the original data, and thus may provide robust video representations. To learn such descriptors, we formulate a subspace learning objective on the Stiefel manifold and resort to Riemannian optimization methods for solving it efficiently. We provide experiments on several video datasets and demonstrate state-of-the-art results.

BPGrad: Towards Global Optimality in Deep Learning via Branch and Pruning

Citation: Zhang, Z.; Wu, Y.; Wang, G., “BPGrad: Towards Global Optimality in Deep Learning via Branch and Pruning”, *IEEE Conference on Computer Vision and Pattern Recognition (CVPR)*, pp. 3301-3309, June 2018.

Contacts: Ziming Zhang

Understanding global optimality in deep learning (DL) has been attracting more and more attention recently. Conventional DL solvers, however, have not been developed intentionally to seek for such global optimality, in general. We propose a novel deep learning solver, namely BPGrad, which has the potential ability of capturing global optimality via branch and pruning. Our solver is based on the assumption that the objective functions in deep learning are Lipschitz continuous. As a result, BPGrad can automatically determine the step size for current gradient given the history of previous solutions, wherein theoretically no smaller step sizes can achieve the global optimality. We show that in theory by repeating such estimation, we can find the global optimality with finite steps.

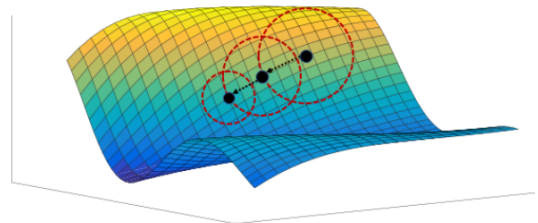

Our solver is based on the assumption that the objective functions in deep learning are Lipschitz continuous. As a result, BPGrad can automatically determine the step size for current gradient given the history of previous solutions, wherein theoretically no smaller step sizes can achieve the global optimality. We show that in theory by repeating such estimation, we can find the global optimality with finite steps.

3D Object Discovery and Modeling Using Single RGB-D Images Containing Multiple Object Instances

Citation: Abbeels, W.; Caccamo, S.; Ataer-Cansizoglu, E.; Taguchi, Y.; Domae, Y., “3D Object Discovery and Modeling Using Single RGB-D Images Containing Multiple Object Instances”, *International Conference on 3D Vision*, Oct 2017
Contacts: Alan Sullivan

We present a method for unsupervised 3D object discovery, reconstruction, and localization that exploits multiple instances of an identical object contained in a single RGB-D image. The proposed method does not rely on segmentation, scene knowledge, or user input, and thus is easily scalable. Our method aims to find recurrent patterns in a single RGB-D image by utilizing appearance and geometry of salient regions. We extract key-points and match them in pairs based on their descriptors. We then generate triplets of the key-points matching with each other using several geometric criteria to minimize false matches. The relative poses of the matched triplets are computed and clustered to discover sets of triplet pairs with similar relative poses. Triplets belonging to the same set are likely to belong to the same object and are used to construct an initial object model. Detection of remaining instances with the initial object model using RANSAC allows us to further expand and refine the model.

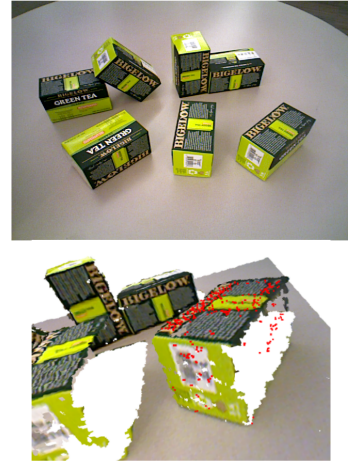

Joint 3D Reconstruction of a Static Scene and Moving Objects

Citation: Caccamo, S.; Ataer-Cansizoglu, E.; Taguchi, Y., “Joint 3D Reconstruction of a Static Scene and Moving Objects”, *International Conference on 3D Vision*, October 2017
Contacts: Alan Sullivan

We present a technique for simultaneous 3D reconstruction of static regions and rigidly moving objects in a scene. An RGB-D frame is represented as a collection of features, which are points and planes. We classify the features into static and dynamic regions and grow separate maps, static and object maps, for each of them. To robustly classify the features in each frame, we fuse multiple RANSAC-based registration results obtained by registering different groups of the features to different maps, including (1) all the features to the static map, (2) all the features to each object map, and (3) subsets of the features, each forming a segment, to each object map. This multi-group registration approach is designed to overcome the following challenges: scenes can be dominated by static regions, making object tracking more difficult; and moving object might have larger pose variation between frames compared to the static regions. We show qualitative results from indoor scenes with objects in various shapes.

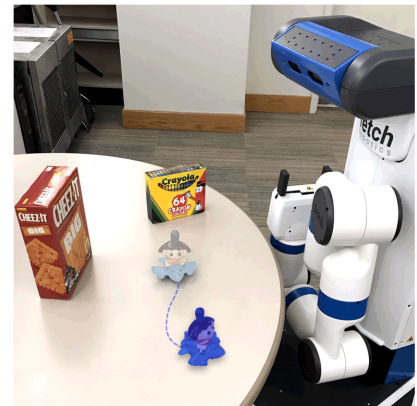

Data Analytics

Data Analytics technologies aim to improve the performance of devices, systems, and business processes by means of collecting data, constructing predictive models from that data, and making improved decisions based on the constructed models. The Data Analytics group at MERL has been working on both predictive and decision analytics, as well as supporting fields such as signal processing, numerical methods, and information systems infrastructure. The focus of the group is on innovative high-performance algorithms that can be applied to various product lines of Mitsubishi Electric, including electrical power systems, various transportation systems (trains, elevators, cars), heating, ventilation, and air conditioning (HVAC) systems and solutions, and factory automation. The application of these algorithms minimizes costs, maximizes profits, increases reliability, improves energy efficiency, and reduces environmental impact of products.

Research on predictive analytics, supported by advances in the fields of statistical machine learning and data management aims to create accurate data-driven models of electromechanical and thermo-dynamical systems, as well as models of complex natural and man-made phenomena such as road traffic and demand for electrical power. The rapidly increasing amount of available sensor data, popularly known as Industrial Big Data, necessitates the development of scalable learning algorithms with computational complexity close to linear in the number of data records.

Decision optimization research emphasizes numerical methods for fast solution of continuous and discrete optimization problems and finds application in the analysis of electrical power systems and Smart Grids that include renewable power sources with intermittent output as well as highly variable loads such as electrical vehicles. Many problems in transportation systems, such as train operation optimization, group elevator scheduling, and car navigation, as well as energy optimization in buildings, can be solved by planning and optimization algorithms. Similarly, a number of problems in robotics, factory automation, and production planning and scheduling can be addressed successfully by means of decision-theoretic planning, sequential optimization, and reinforcement learning methods.

Recent Research

Derivative-Free Semiparametric Bayesian Models for Robot Learning	52
Learning Tasks in a Complex Circular Maze Environment.....	52
Derivative-Free Online Learning of Inverse Dynamics Models	53
Learning Dynamical Demand Response Model in Real-Time Pricing Program	53
Algorithms for Task Allocation in Homogeneous Swarm of Robots.....	54
Anomaly Detection in Discrete Manufacturing Systems using Event Relationship Tables.....	54
Consensus-based Synchronization of Microgrids at Multiple Points of Interconnection.....	55
Learning-Based Iterative Modular Adaptive Control for Nonlinear Systems	55
Reinforcement Learning with ... Action Spaces for Partial Differential Equation Control.....	56
On the Minimum Chordal Completion Polytope	56
A Hybrid Adaptive Feedback Law for Robust Obstacle Avoidance and Coordination in	57
The Integrated Last-Mile Transportation Problem (ILMTP).....	57
... Dynamic Programming Approach for Energy and Reserve Management of Power Plants	58
Finding Multidimensional Patterns in Multidimensional Time Series.....	58

Derivative-Free Semiparametric Bayesian Models for Robot Learning

Citation: Romeres, D.; Jha, D.; Dalla Libera, A.; Chiuso, A.; Nikovski, D.N.,
“Derivative-Free Semiparametric Bayesian Models for Robot Learning”,
Advances in Neural Information Processing Systems (NIPS), December 2018.
Contacts: Diego Romeres, Devesh Jha, Daniel N. Nikovski

Model-Based Reinforcement Learning (MBRL) is gaining much interest in the robot learning community; in MBRL, the model serves as a representation which is largely task-invariant, and thus can facilitate transfer of knowledge across multiple tasks in the same domain. Learning reliable models for physical systems, however, remains a challenging problem. This paper summarizes recent semiparametric and derivative-free modelling techniques, and presents some key points for a new methodology to formulate derivative-free semiparametric Bayesian models with applications to robot learning. The modeling technique is demonstrated using a real robotic system, and is shown to consistently perform better than other state-of-the-art techniques.



Learning Tasks in a Complex Circular Maze Environment

Citation: Jha, D.; Romeres, D.; van Baar, J.; Sullivan, A.; Nikovski, D.N., “Learning Tasks in a Complex Circular Maze Environment”, *Modeling the Physical World: Perception, Learning, and Control, NIPS Workshop*, December 2018.
Contacts: Devesh Jha, Diego Romeres, Jeroen van Baar, Alan Sullivan, Daniel N. Nikovski

The purpose of this article is to introduce a circular maze system as a challenging environment to solve, which could be of interest to the robot and reinforcement learning community. Recently, there have been rapid developments in the fields of machine and reinforcement learning, largely due to the success of deep learning approaches. This has also led to increased interest in the area of learning physics based systems. The



circular maze environment that we present here is a low-DoF complex system which could be used to investigate many interesting learning problems. We propose some initial results using both model-free and model-based learning approaches to solve the environment with a single and multiple marbles, to demonstrate some of the challenges that this system presents. We hope to open-source the simulation software and hardware design details of the system in the near future.

Derivative-Free Online Learning of Inverse Dynamics Models

Citation: Romeres, D.; Zorzi, M.; Camoriano, R.; Traversaro, S.; Chiuso, A., “Derivative-Free Online Learning of Inverse Dynamics Models”, *IEEE Transactions on Control Systems Technology*, DOI: 10.1109/TCST.2019.2891222, March 2019.

Contacts: Diego Romeres

This paper discusses online algorithms for inverse dynamics modelling in robotics. Several model classes including rigid body dynamics (RBD) models, data-driven models and semiparametric models (which are a combination of the previous two classes) are placed in a common framework. While model classes used in the literature typically exploit joint velocities and accelerations, which need to be approximated resorting to numerical differentiation schemes, in this paper a new “derivative-free” framework is proposed that does not require this preprocessing step. An extensive experimental study with real data from the right arm of the iCub robot is presented, comparing different model classes and estimation procedures, showing that our “derivative-free” methods outperform existing methodologies.

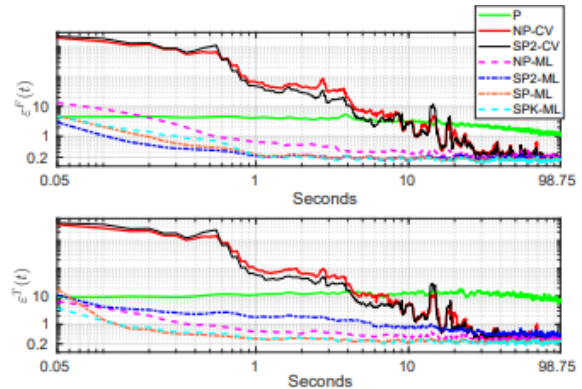

Learning Dynamical Demand Response Model in Real-Time Pricing Program

Citation: Xu, H.; Sun, H.; Nikovski, D.N.; Shoichi, K.; Mori, K., “Learning Dynamical Demand Response Model in Real-Time Pricing Program”, *IEEE ISGT*, February 2019.

Contacts: Hongbo Sun, Daniel N. Nikovski

Price responsiveness is a major feature of end use customers (EUCs) that participate in demand response (DR) programs, and has been conventionally modeled with static demand functions, which take the electricity price as the input and the aggregate energy consumption as the output. This, however, neglects the inherent temporal correlation of the EUC behaviors, and may result in large errors when predicting the actual responses of EUCs in real-time pricing (RTP) programs. In this paper, we propose a dynamical DR model so as to capture the temporal behavior of the EUCs. The states in the proposed dynamical DR model can be explicitly chosen, in which case the model can be represented by a linear function or a multi-layer feedforward neural network, or implicitly chosen, in which case the model can be represented by a recurrent neural network or a long short-term memory unit network. In both cases, the dynamical DR model can be learned from historical price and energy consumption data. Numerical simulation illustrated how the states are chosen and also showed the proposed dynamical DR model significantly outperforms static ones.

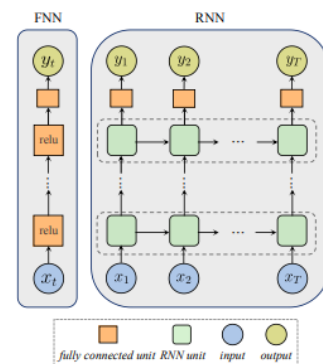

Algorithms for Task Allocation in Homogeneous Swarm of Robots

Citation: Jha, D., “Algorithms for Task Allocation in Homogeneous Swarm of Robots”, *IEEE/RSJ International Conference on Intelligent Robots and Systems (IROS)*, DOI: 10.1109/IROS.2018.8594052, October 2018.

Contacts: Devesh Jha

We present algorithms for synthesizing controllers to distribute a swarm of homogeneous robots (agents) over heterogeneous tasks which are operated in parallel. A swarm is modeled as a homogeneous collection of irreducible Markov chains. States of the Markov chain represent the tasks performed by the swarm. The target state is a pre-defined distribution of agents over the states of the Markov chain (and thus the tasks). We make use of ergodicity property of irreducible Markov chains to ensure that as an individual agent converges to the desired behavior in time, the swarm converges to the target state. To circumvent the problems faced by a global controller and local/decentralized controllers alone, we design a controller by combining global supervision with local-feedback-based state level decisions.

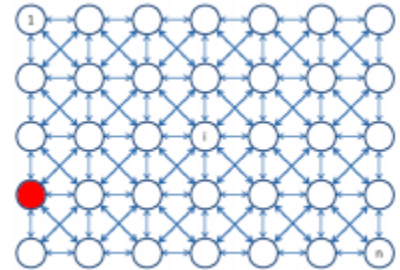

Anomaly Detection in Discrete Manufacturing Systems using Event Relationship Tables

Citation: Laftchiev, E.; Sun, X.; Dau, H.-A.; Nikovski, D.N., “Anomaly Detection in Discrete Manufacturing Systems using Event Relationship Tables”, *International Workshop on Principle of Diagnosis*, August 2018.

Contacts: Emil Laftchiev, Daniel N. Nikovski

Anomalies in discrete manufacturing processes (DMPs) can result in reduced product quality, production delays, and physical danger to employees. It is difficult to detect anomalies in DMPs, because sequencing devices such as programmable logic controllers (PLCs) usually do not allow a process engineer to easily determine which sequences of operations are observed and checking against each sequence becomes computationally difficult. This paper proposes a new anomaly detection approach for discrete manufacturing systems. The approach models the normal behavior of the DMP from the PLC output as event relationship tables. These models are then used to determine if new sequences of PLC outputs could be generated by the system. Outputs that do not fit the learned model are labeled anomalous. This method is tested in simulation for DMPs that contain concurrent sub-process with unique or repeated events. The results are compared to a baseline method proposed in prior publications. Experiments show that the proposed algorithms are capable of achieving a higher F-score with less than 10% of the data required by the baseline method.

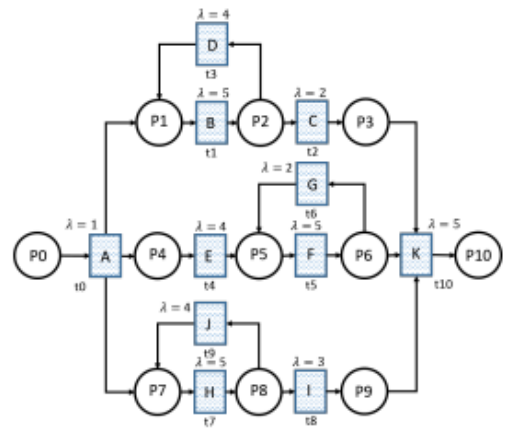

Consensus-based Synchronization of Microgrids at Multiple Points of Interconnection

Citation: Shah, S.; Sun, H.; Nikovski, D.N.; Zhang, J., “Consensus-based Synchronization of Microgrids at Multiple Points of Interconnection”, *IEEE Power & Energy Society General Meeting*, DOI: 10.1109/PESGM.2018.8586167, August 2018.

Contacts: Hongbo Sun, Daniel N. Nikovski, Jinyun Zhang

This paper presents a consensus-based distributed synchronization control method for microgrids with multiple points of interconnection. The proposed method can synchronize a microgrid at different points of interconnection using a common sparse communication network among its distributed generators. This functionality is critical for the networked operation of multiple microgrids in the future power systems. The proposed approach uses averaging and leader-follower modes of a commonly used consensus algorithm for multi-agent systems to achieve microgrid synchronization and smooth transition between the islanded and grid-connected modes at different interconnection points. The operation of the proposed distributed synchronization method is demonstrated on a microgrid with four inverters.

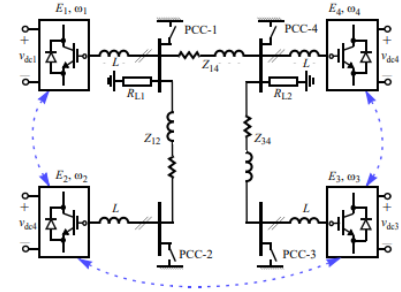

Learning-Based Iterative Modular Adaptive Control for Nonlinear Systems

Citation: Benosman, M.; Farahmand, A.-M.; Xia, M., “Learning-Based Iterative Modular Adaptive Control for Nonlinear Systems”, *International Journal of Adaptive Control and Signal Processing*, DOI: 10.1002/acs.2892, August 2017.

Contacts: Mouhacine Benosman

We study the problem of adaptive trajectory tracking control for a class of nonlinear systems with structured parametric uncertainties. We propose to use an iterative modular approach: we first design a robust nonlinear state feedback that renders the closed-loop input-to-state stable (ISS). Here, the input is considered to be the estimation error of the uncertain parameters, and the state is considered to be the closed-loop output tracking error. Next, we propose an iterative adaptive algorithm, where we augment this robust ISS controller with an iterative data-driven learning algorithm to estimate online the parametric uncertainties of the model. We implement this method with two different learning approaches. The first one is a data-driven multiparametric extremum-seeking method, which guarantees local convergence results, and the second is a Bayesian optimization-based method called Gaussian Process Upper Confidence Bound, which guarantees global results in a compact search set. The combination of the ISS feedback and the data-driven learning algorithms gives a learning-based modular indirect adaptive controller.

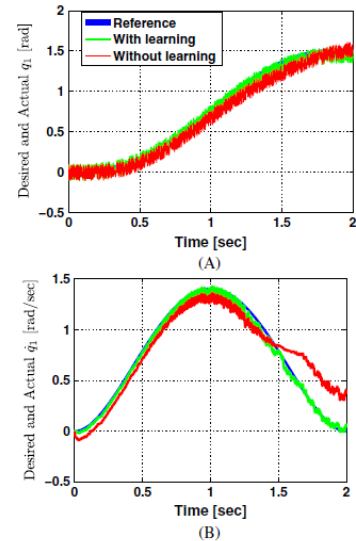

Reinforcement Learning with Function-Valued Action Spaces for Partial Differential Equation Control

Citation: Pan, Y.; Farahmand, A.-M.; White, M.; Nabi, S.; Grover, P.; Nikovski, D.N., “Reinforcement Learning with Function-Valued Action Spaces for Partial Differential Equation Control”, *International Conference on Machine Learning (ICML)*, July 2018.

Contacts: Saleh Nabi, Piyush Grover, Daniel N. Nikovski

Recent work has shown that reinforcement learning (RL) is a promising approach to control dynamical systems described by partial differential equations (PDEs). This paper shows how to use RL to tackle more general PDE control problems that have continuous high-dimensional action spaces with spatial relationship among action dimensions. In particular, we propose the concept of action descriptors, which encode regularities among spatially-extended action dimensions and enable the agent to control high-dimensional action PDEs. We provide theoretical evidence suggesting that this approach can be more sample efficient compared to a conventional approach that treats each action dimension separately and does not explicitly exploit the spatial regularity of the action space. Experiments on two PDE control problems, with up to 256-dimensional continuous actions, show the advantage of the proposed approach over conventional ones.

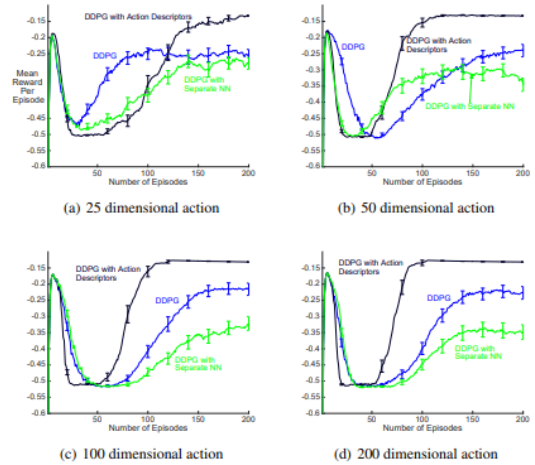

On the Minimum Chordal Completion Polytope

Citation: Bergman, D.; Cardonha, C.; Cire, A.; Raghunathan, A.U., “On the Minimum Chordal Completion Polytope”, *Operations Research*, DOI: 10.1287/opre.2018.1783, vol. 67, pp. 295-597, March 2019.

Contacts: Arvind Raghunathan

A graph is chordal if every cycle of length at least four contains a chord, that is, an edge connecting two nonconsecutive vertices of the cycle. Several classical applications in sparse linear systems, database management, computer vision, and semidefinite programming can be reduced to finding the minimum number of edges to add to a graph so that it becomes chordal, known as the minimum chordal completion problem (MCCP). We propose a new formulation for the MCCP that does not rely on finding perfect elimination orderings of the graph, as has been considered in previous work. We introduce several families of facet-defining inequalities for cycle subgraphs and investigate the underlying separation problems, showing that some key inequalities are NP-Hard to separate. We also identify conditions through which facets and inequalities associated with the polytope of a certain graph can be adapted in order to become facet defining for some of its subgraphs or super-graphs.

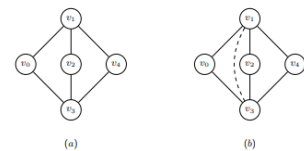

A Hybrid Adaptive Feedback Law for Robust Obstacle Avoidance and Coordination in Multiple Vehicle Systems

Citation: Poveda, J.; Benosman, M.; Teel, A.; Sanfelice, R.G., “A Hybrid Adaptive Feedback Law for Robust Obstacle Avoidance and Coordination in Multiple Vehicle Systems”, *American Control Conference (ACC)*, DOI: 10.23919/ACC.2018.8431064, pp. 616-621, June 2018.

Contacts: Mouhacine Benosman

This paper presents an adaptive hybrid feedback law designed to robustly steer a group of autonomous vehicles toward the source of an unknown but measurable signal, at the same time that an obstacle is avoided and a prescribed formation is maintained. The hybrid law overcomes the limitations imposed by the topological obstructions induced by the obstacle, which precludes the robust stabilization of the source if the signal by using smooth feedback. The control strategy implements a leader-follower approach, where the followers track, in a coordinated way, the position of the leader.

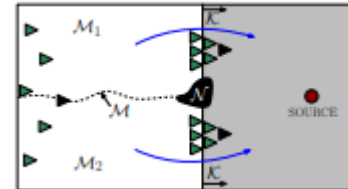

The Integrated Last-Mile Transportation Problem (ILMTP)

Citation: Raghunathan, A.U.; Bergman, D.; Hooker, J.; Serra, T.; Kobori, S., “The Integrated Last-Mile Transportation Problem (ILMTP)”, *International Conference on Automated Planning and Scheduling (ICAPS)*, June 2018.

Contacts: Arvind Raghunathan, Thiago Serra

Last-mile transportation (LMT) refers to any service that moves passengers from a hub of mass transportation (MT), such as air, boat, bus, or train, to destinations, such as a home or an office. In this paper, we introduce the problem of scheduling passengers jointly on MT and LMT services, with passengers sharing a car, van, or autonomous pod of limited capacity for LMT. Passenger itineraries are determined so as to minimize

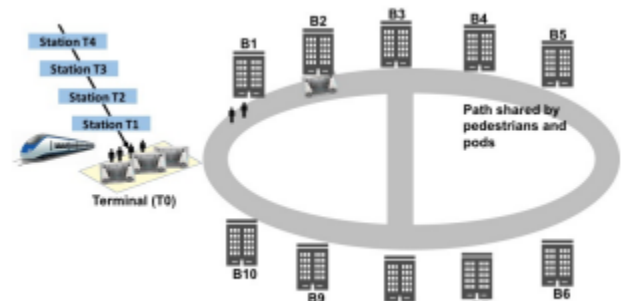

total transit time for all passengers, with each passenger arriving at the destination within a specified time window. The transit time includes the time spent traveling through both services and, possibly, waiting time for transferring between the services. We provide an integer linear programming (ILP) formulation for this problem. Since the ILMTP is NP-hard and problem instances of practical size are often difficult to solve, we study a restricted version where MT trips are uniform, all passengers have time windows of a common size, and LMT vehicles visit one destination per trip. We prove that there is an optimal solution that sorts and groups passengers by their deadlines and, based on this result, we propose a constructive grouping heuristic and local search operators to generate high-quality solutions. The resulting groups are optimally scheduled in a few seconds using another ILP formulation.

Machine Learning Based State-Space Approximate Dynamic Programming Approach for Energy and Reserve Management of Power Plants

Citation: Keerthisinghe, C.; Sun, H.; Takaguchi, Y.; Nikovski, D.N.; Hashimoto, H., “Machine Learning Based State-Space Approximate Dynamic Programming Approach for Energy and Reserve Management of Power Plants”, *IEEE PES Innovative Smart Grid Technologies Asia (ISGT Asia)*, DOI: 10.1109/ISGT-Asia.2018.8467807, pp. 669-674, May 2018.

Contacts: Mouhacine Benosman

This paper proposes a machine learning based state-space approximate dynamic programming (MSADP) approach to solve the self-scheduling problem faced by power plants under an integrated energy and reserve market. By extending the concept of residual demand curves (RDCs) from energy to reserve, residual reserve curves (RRCs) are proposed to model the regulation price as a function of the power plant’s reserve power. Both RRCs and RDCs are obtained using a clustering based neural network approach, which resulted in better estimates than using only a non-parametric approach. The machine learning is used to make approximations to the state space, and the dynamic programming only loops over the required states. As such, the computation effort is reduced but the solution quality is not impacted.

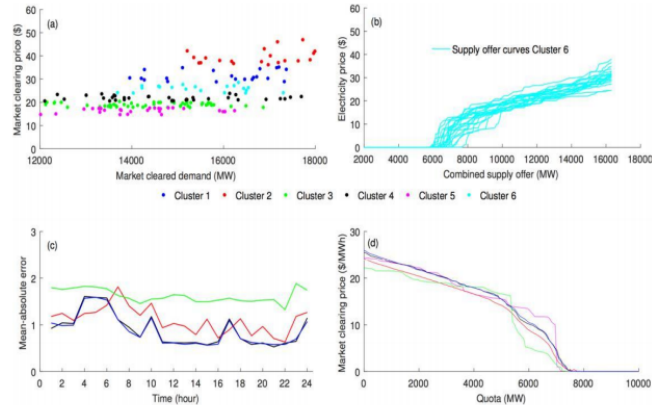

Finding Multidimensional Patterns in Multidimensional Time Series

Citation: Laftchiev, E.; Liu, Y., “Finding Multidimensional Patterns in Multidimensional Time Series”, *SIGKDD Workshop on Mining and Learning From Time Series*, August 2018 (TR2018-044).

Contacts: Emil Laftchiev

Exact pattern matching is a method of localizing arbitrarily sized patterns in time series data. To date, the problem of exact pattern matching has only been fully addressed for one query pattern on one time series with a single best match location. This paper addresses the broader problem of finding the top-K pattern matches for a multidimensional time series pattern in a large multidimensional time series. The problem is addressed in two stages using an algorithm that combines ideas from the fields of data mining and bi-clustering. The first stage of the algorithm addresses selecting the dimension subset that matches the query pattern and locating the matching pattern. The second stage of the algorithm addresses the problem of finding the top-K matches of the pattern in the selected time series dimensions.



Speech & Audio

The speech and audio group pursues a range of challenging machine-perception problems, involving acoustic signals, human language, and everything in between. Our primary areas of research cover speech enhancement and separation, speech recognition, natural language processing, and acoustic analysis.

In the area of speech enhancement and separation, we have developed novel techniques to effectively separate the speech of simultaneous speakers, with either single microphone or multiple microphone configurations. Prior work has also addressed the suppression of various types of background noises from the speech signal.

For speech recognition, we have been advancing the state-of-the-art in end-to-end deep learning approaches, which simplify conventional systems into single network architecture that can be fully optimized without the need for expert knowledge such as phoneme set, pronunciation lexicon, and tokenization. Furthermore, we have enabled extensions for multiple languages, multiple simultaneous speakers, and their combination.

Our efforts in natural language processing target advanced spoken dialog systems based on neural conversation models, in which we generate system responses automatically based on the user input directly, without the need for any intermediate symbols or annotation. We extend this work to scene-aware dialog systems that respond to multiple audio-visual cues in the scene.

Research in the area of acoustic analysis targets the diagnostics and optimization of industrial machines for improved efficiency and cost reduction. We also aim to classify general sounds in complex mixtures in order to enable more comprehensive scene understanding.

Recent Research

Phasebook and Friends: Leveraging discrete representations for source separation.....	60
End-to-End Speech Recognition with Word-Based RNN Language Models.....	60
Adversarial Training and Decoding Strategies for End-to-end Neural Conversation Models.....	61
Phase Reconstruction with Learned ... Representations for Single-Channel Speech Separation.	61
A Purely End-to-end System for Multi-speaker Speech Recognition	62
... Spectral and Spatial Embeddings for Speaker-Independent Speech Separation	62
End-to-End Multi-Speaker Speech Recognition	63

Phasebook and Friends: Leveraging discrete representations for source separation

Citation: Le Roux, J., Wichern, G., Watanabe, S., Sarroff, A., Hershey, J., "Phasebook and Friends: Leveraging discrete representations for source separation", *IEEE Journal of Selected Topics in Signal Processing*, March 2019.

Contacts: Jonathan Le Roux, Gordon Wichern

Deep learning based speech enhancement and source separation systems have recently reached unprecedented levels of quality, to the point that performance is reaching a new ceiling. A limiting factor in such approaches is a lack of phase estimation: the phase of the mixture is most often used when reconstructing the estimated time-domain signal. Here, we propose “magbook”, “phasebook”, and “combook”, three new types of layers based on discrete representations that can be used to estimate complex time-frequency masks. Magbook layers extend classical sigmoidal units and a recently introduced convex softmax activation for mask-based magnitude estimation. Phasebook layers use a similar structure to give an estimate of the phase mask without suffering from phase wrapping issues. Combook layers are an alternative to the magbook/phasebook combination that directly estimate complex masks.

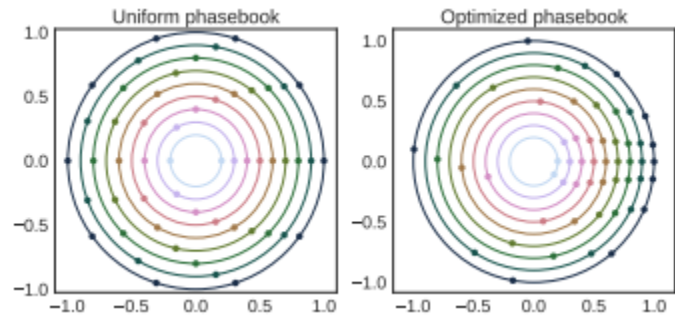

End-to-End Speech Recognition with Word-Based RNN Language Models

Citation: Hori, T.; Cho, J.; Watanabe, S., “End-to-End Speech Recognition with Word-Based RNN Language Models”, *IEEE Spoken Language Technology Workshop*, DOI: 10.1109/SLT.2018.8639693, December 2018.

Contacts: Takaaki Hori

This paper investigates the impact of word-based RNN language models (RNN-LMs) on the performance of end-to-end automatic speech recognition (ASR). In our prior work, we have proposed a multi-level LM, in which character-based and word-based RNNLMs are combined in hybrid CTC/attention-based ASR. Although this multi-level approach achieves significant error reduction in the Wall Street Journal (WSJ) task, two different LMs need to be trained and used for decoding, which

increase the computational cost and memory usage. In this paper, we further propose a novel word-based RNN-LM, which allows us to decode with only the word-based LM, where it provides look-ahead word probabilities to predict next characters instead of the character-based LM, leading competitive accuracy with less computation compared to the multi-level LM.

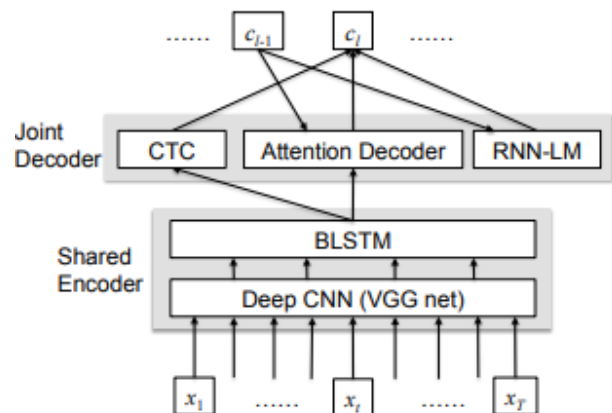

Adversarial Training and Decoding Strategies for End-to-end Neural Conversation Models

Citation: Hori, T.; Wang, W.; Koji, Y.; Hori, C.; Harsham, B.A.; Hershey, J., “Adversarial Training and Decoding Strategies for End-to-end Neural Conversation Models”, *Computer Speech and Language*, DOI: 10.1016/j.csl.2018.08.006, vol. 54, pp. 122-139, December 2018.

Contacts: Takaaki Hori, Chiori Hori, Bret A. Harsham

This paper presents adversarial training and decoding methods for neural conversation models that can generate natural responses given dialog contexts. In our prior work, we built several end-to-end conversation systems for the 6th Dialog System Technology Challenges (DSTC6) Twitter help-desk dialog task. These systems included novel extensions of sequence adversarial training, example-based response extraction, and Minimum Bayes-Risk based system combination. In

DSTC6, our systems achieved the best performance in most objective measures such as BLEU and METEOR scores and decent performance in a subjective measure based on human rating. In this paper, we provide a complete set of our experiments for DSTC6 and further extend the training and decoding strategies more focusing on improving the subjective measure, where we combine responses of three adversarial models. Experimental results demonstrate that the extended methods improve the human rating score and outperform the best score in DSTC6.

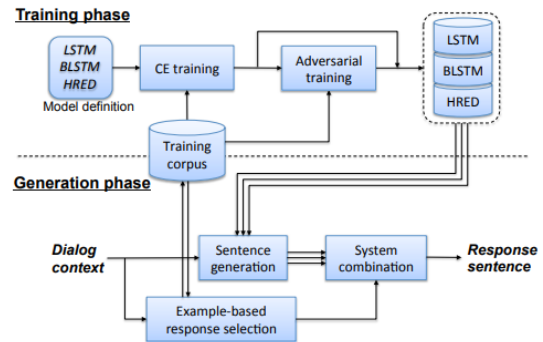

Phase Reconstruction with Learned Time-Frequency Representations for Single-Channel Speech Separation

Citation: Wichern, G.; Le Roux, J., “Phase Reconstruction with Learned Time-Frequency Representations for Single-Channel Speech Separation”, *International Workshop on Acoustic Signal Enhancement (IWAENC)*, DOI: 10.1109/IWAENC.2018.8521243, September 2018.

Contacts: Gordon Wichern, Jonathan Le Roux

Progress in solving the cocktail party problem, i.e., separating the speech from multiple overlapping speakers, has recently accelerated with the invention of techniques

such as deep clustering and permutation free mask inference. These approaches typically focus on estimating target STFT magnitudes and ignore problems of phase inconsistency. In this paper, we explicitly integrate phase reconstruction into our separation algorithm using a loss function defined on time-domain signals. A deep neural network structure is defined by unfolding a phase reconstruction algorithm and treating each iteration as a layer in our network. Furthermore, instead of using fixed STFT/iSTFT time-frequency representations, we allow our network to learn a modified version of these representations from data.

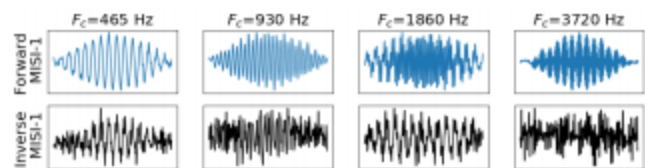

A Purely End-to-end System for Multi-speaker Speech Recognition

Citation: Seki, H., Hori, T., Watanabe, S., Le Roux, J., Hershey, J., "A Purely End-to-end System for Multi-speaker Speech Recognition", *Annual Meeting of the Association for Computational Linguistics (ACL)*, July 2018.

Contacts: Takaaki Hori, Jonathan Le Roux

Recently, there has been growing interest in multi-speaker speech recognition, where the utterances of multiple speakers are recognized from their mixture. Promising techniques have been proposed for this task, but earlier works have required additional training data such as isolated source signals or senone alignments for effective learning. In this paper, we propose a new sequence-to-sequence framework to directly decode multiple label sequences from a single speech sequence by unifying source separation and speech recognition functions in an end-to-end manner. We further propose a new objective function to improve the contrast between the hidden vectors to avoid generating similar hypotheses. Experimental results show that the model is directly able to learn a mapping from a speech mixture to multiple label sequences, achieving 83.1% relative improvement compared to a model trained without the proposed objective.

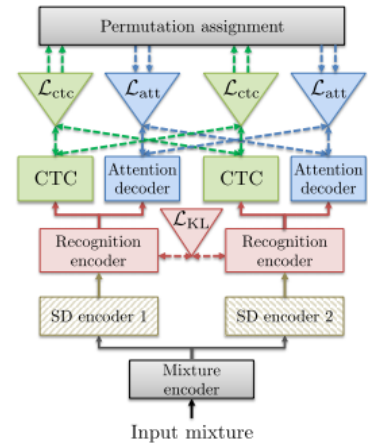

Multi-Channel Deep Clustering: Discriminative Spectral and Spatial Embeddings for Speaker-Independent Speech Separation

Citation: Wang, Z.-Q.; Le Roux, J.; Hershey, J.R., "Multi-Channel Deep Clustering: Discriminative Spectral and Spatial Embeddings for Speaker-Independent Speech Separation", *IEEE International Conference on Acoustics, Speech, and Signal Processing (ICASSP)*, DOI: 10.1109/ICASSP.2018.8461639, pp. 1-5, April 2018.

Contacts: Jonathan Le Roux

The recently-proposed deep clustering algorithm represents a fundamental advance towards solving the cocktail party problem in the single-channel case. When multiple microphones are available, spatial information can be leveraged to differentiate signals from different directions. This study combines spectral and spatial features in a deep clustering framework so that the complementary spectral and spatial information can be simultaneously exploited to improve speech separation. We find that simply encoding inter-microphone phase patterns as additional input features during deep clustering provides a significant improvement in separation performance, even with random microphone array geometry. Experiments on a spatialized version of the wsj0-2mix dataset show the potential of our algorithm for speech separation in reverberant environments.

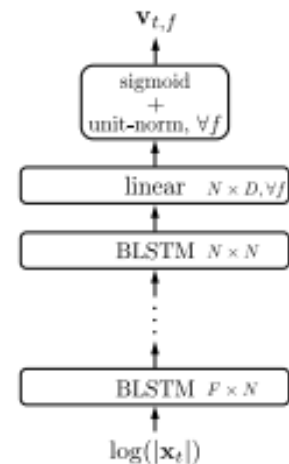

End-to-End Multi-Speaker Speech Recognition

Citation: Settle, S.; Le Roux, J.; Hori, T.; Watanabe, S.; Hershey, J.R., “End-to-End Multi-Speaker Speech Recognition”, IEEE International Conference on Acoustics, Speech, and Signal Processing (ICASSP), DOI:

10.1109/ICASSP.2018.8461893, pp. 4819-4823, April 2018.

Contacts: Jonathan Le Roux, Takaaki Hori

Current advances in deep learning have resulted in a convergence of methods across a wide range of tasks, opening the door for tighter integration of modules that were previously developed and optimized in isolation. Recent ground-breaking works have produced end-to-end deep network methods for both speech separation and end-to-end automatic speech recognition (ASR). Although these two components can be trained in isolation and connected after the fact, this paradigm is likely to be sub-optimal, since it relies on artificially mixed data. In this paper, we develop the first fully end-to-end, jointly trained deep learning system for separation and recognition of overlapping speech signals. The joint training framework synergistically adapts the separation and recognition to each other. As an additional benefit, it enables training on more realistic data that contains only mixed signals and their transcriptions, and thus is suited to large scale training on existing transcribed data.

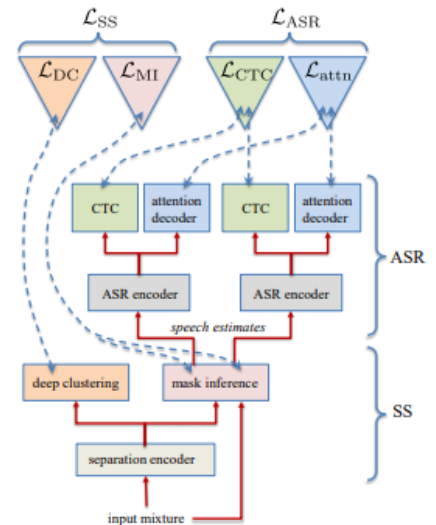

Signal Processing

The Signal Processing Group conducts fundamental and applied research in the areas of wireless and optical communications, computational sensing, and optical and RF semiconductor devices. Our research has application to product areas such as terrestrial and trans-oceanic optical networks, train and automotive connectivity, mobile cellular, networking for IoT, RF power amplifiers, vehicular radars, non-contact sensing and radar imaging.

Wireless research focuses on the development of novel physical and network layer algorithms, RF device design with advanced signal processing, to enable high reliability wireless networks for IoT networks, millimeter wave and THz systems and vehicular networks. We also seek to apply signal processing and communications knowledge to areas such as cooperative robotics, radio-based localization, and applied estimation and optimization algorithms for applications such as IoT, battery monitoring, and smart grid.

Optical research focuses on transceiver signal processing algorithms and error control coding for coherent fiber-optical communications, and the development of novel photonic integrated circuits to support coherent optical communications applications.

Computational sensing research exploits widely available computational power to overhaul the signal acquisition paradigm and significantly enhance sensing capabilities. Our research aims to fundamentally understand how signals behave and propagate in the environment and develops reconstruction algorithms to recover these signals.

Recent Research

Deep Neural Network Inverse Design of Integrated Photonic Power Splitters	66
On Angular-Domain Channel Estimation for One-Bit Massive MIMO Systems with	66
Multiset-Partition Distribution Matching.....	67
Transfer Learning in Brain-Computer Interfaces with Adversarial Variational Autoencoders....	67
Terahertz Imaging of Binary Reflectance with Variational Bayesian Inference.....	68
Polar-Coded Modulation for Joint Channel Coding and Probabilistic Shaping.....	68
Sparse Blind Deconvolution for Distributed Radar Autofocus Imaging	69
High-Resolution Lidar Using Random Demodulation	69
Machine-Learning Based Digital Doherty Power Amplifier	70
Anomaly Detection in Manufacturing Systems Using Structured Neural Networks	70
Frequency Noise Reduction of Integrated Laser Source with On-Chip Optical Feedback	71
Remaining Useful Life Estimation of Batteries using Dirichlet Process with	71

Deep Neural Network Inverse Design of Integrated Photonic Power Splitters

Citation: TaherSima, M., Kojima, K., Koike-Akino, T., Jha, D., Wang, B., Lin, C., Parsons, K., "Deep Neural Network Inverse Design of Integrated Photonic Power Splitters", *Nature Scientific Reports*, December 2018.

Contacts: Keisuke Kojima, Toshiaki Koike-Akino, Devesh Jha, Bingnan Wang, Chungwei Lin

Predicting physical response of an artificially structured material is of particular interest for scientific and engineering applications. Here we use deep learning to predict optical response of artificially engineered nanophotonic devices. In addition to predicting forward approximation of transmission response for any given topology, this approach allows us to inversely approximate designs for a targeted optical response. Our Deep Neural Network (DNN) could design compact ($2.6 \times 2.6 \mu\text{m}^2$) silicon-on-insulator (SOI)-based 1x2 power splitters with various target splitting ratios in a fraction of a second. This model is trained to minimize the reflection (to smaller than -20 dB) while achieving maximum transmission efficiency above 90% and target splitting specifications. This approach paves the way for rapid design of integrated photonic components relying on complex nanostructures.

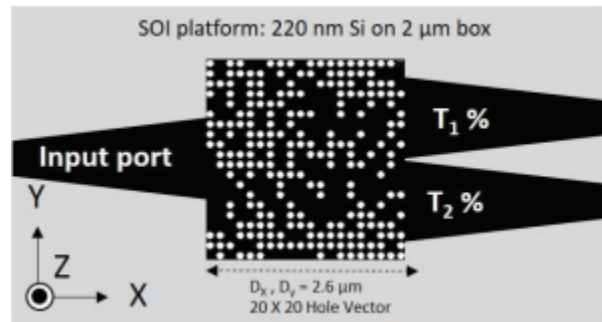

On Angular-Domain Channel Estimation for One-Bit Massive MIMO Systems with Fixed and Time-Varying Thresholds

Citation: Wang, P.; Li, J.; Pajovic, M.; Boufounos, P.T.; Orlik, P.V., "On Angular-Domain Channel Estimation for One-Bit Massive MIMO Systems with Fixed and Time-Varying Thresholds", *Asilomar Conference on Signals, Systems and Computers (ACSSC)*, DOI: 10.1109/ACSSC.2017.8335511, December 2017.

Contacts: Pu (Perry) Wang, Milutin Pajovic, Petros T. Boufounos, Philip V. Orlik

This paper considers angular-domain channel estimation for massive MIMO systems with one-bit analog-to-digital converters (ADCs) equipped at base stations for the sake of lower power consumption and reduced hardware cost. We characterize analytical performance, in terms of the Cramer-Rao bound (CRB), on estimating the two-dimensional channel matrix (including angle-of-departure, angle-of-arrival and associated channel path gains) in the angular-domain representation. Our analysis provides a simple tool to compare the channel estimation performance among several one-bit quantization schemes. Particularly, we study the performance trade-off between fixed (zero-threshold) and time-varying one-bit quantization schemes. Numerical results are provided for analytical performance verification as a function of SNR and the number of pilots.

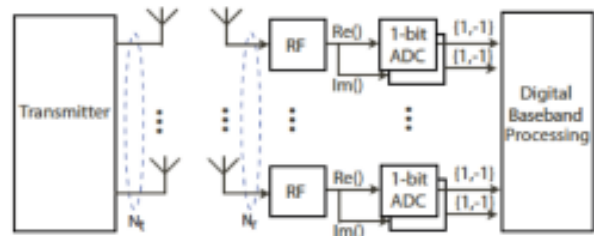

Multiset-Partition Distribution Matching

Citation: Fehenberger, T., Millar, D.S., Koike-Akino, T., Kojima, K., Parsons, K., "Multiset-Partition Distribution Matching", *IEEE Transactions on Communications*, DOI: 10.1109/TCOMM.2018.2881091, December 2018.
 Contacts: David Millar, Toshiaki Koike-Akino, Keisuke Kojima, Kieran Parsons

Distribution matching is a fixed-length invertible mapping from a uniformly distributed bit sequence to shaped amplitudes and plays an important role in the probabilistic amplitude shaping framework. With conventional constant composition distribution matching (CCDM), all output sequences have identical composition. In this paper, we propose multiset partition distribution matching (MPDM) where the composition is constant over all output sequences. When

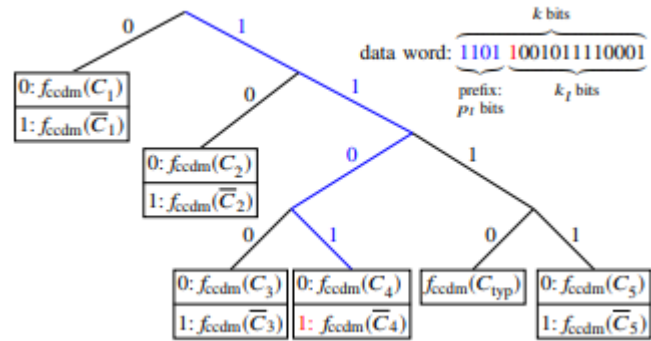

considering the desired distribution as a multiset, MPDM corresponds to partitioning this multiset into equal-size subsets. Simulations of 64-ary quadrature amplitude modulation over the additive white Gaussian noise channel demonstrate that the block-length saving of MPDM over CCDM for a fixed gap to capacity is approximately a factor of 2.5 to 5 at medium to high signal-to-noise ratios (SNRs).

Transfer Learning in Brain-Computer Interfaces with Adversarial Variational Autoencoders

Citation: Ozdenizci, O.; Wang, Y.; Koike-Akino, T.; Erdogmus, D., "Transfer Learning in Brain-Computer Interfaces with Adversarial Variational Autoencoders", International IEEE EMBS Conference on Neural Engineering, DOI: 10.1109/NER.2019.8716897, March 2019.
 Contacts: Ye Wang, Toshiaki Koike-Akino

We introduce adversarial neural networks for representation learning as a novel approach to transfer learning in brain-computer interfaces (BCIs). The proposed approach aims to learn subject-invariant representations by simultaneously training a conditional variational autoencoder (cVAE) and an adversarial network. We use shallow convolutional architectures to realize the cVAE, and the learned encoder is transferred to extract subject-invariant features from unseen BCI users' data for decoding. We demonstrate a proof-of-concept of our approach based on analyses of electroencephalographic (EEG) data recorded during a motor imagery BCI experiment.

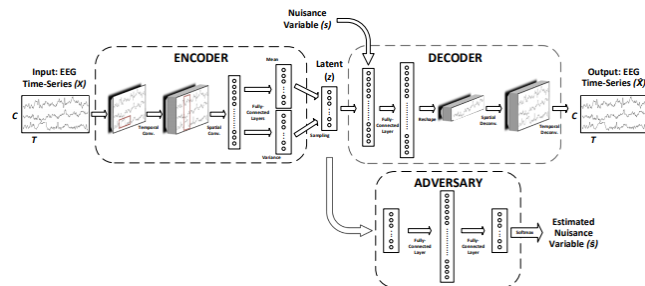

Terahertz Imaging of Binary Reflectance with Variational Bayesian Inference

Citation: Fu, H., Wang, P., Koike-Akino, T., Orlik, P.V., Chi, Y., "Terahertz Imaging of Binary Reflectance with Variational Bayesian Inference", *IEEE International Conference on Acoustics, Speech, and Signal Processing (ICASSP)*, DOI: 10.1109/ICASSP.2018.8461987, pp. 3394-3398, April 2018.

Contacts: Pu Wang, Toshiaki Koike-Akino, Philip Orlik

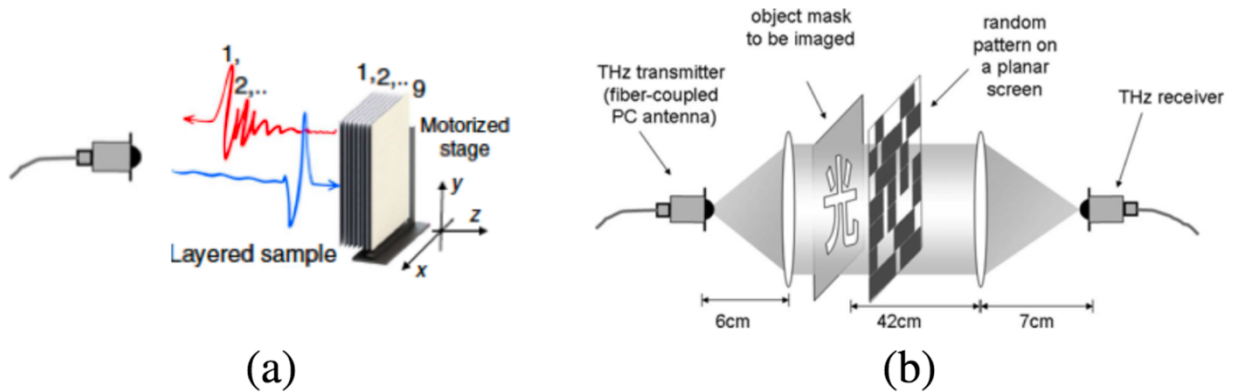

In this paper, we propose a Bayesian inference approach to extract the binary reflectance pattern of samples from compressed measurements in the terahertz (THz) frequency band. Compared with existing compressed THz imaging methods relying on the sparsity of the reflectance pattern, the proposed Bayesian approach exploits the non-negative binary nature of the reflectance without any assumption on its spatial pattern information and enables a pixel-wise iterative inference approach for fast signal recovery. Numerical evaluation confirms the effectiveness of the proposed approach.

Polar-Coded Modulation for Joint Channel Coding and Probabilistic Shaping

Citation: Matsumine, T., Koike-Akino, T., Millar, D.S., Kojima, K., Parsons, K., "Polar-Coded Modulation for Joint Channel Coding and Probabilistic Shaping", *Optical Fiber Communication Conference and Exposition and the National Fiber Optic Engineers Conference (OFC/NFOEC)*, DOI: 10.1364/OFC.2019.M4B.2, March 2019.

Contacts: Toshiaki Koike-Akino, David Millar, Keisuke Kojima, Kieran Parsons

We propose joint channel coding and constellation shaping based on polar-coded modulation. The proposed shaping method offers greater than 0.6 dB gain without the need of an external distribution matcher and the increase of decoding complexity.

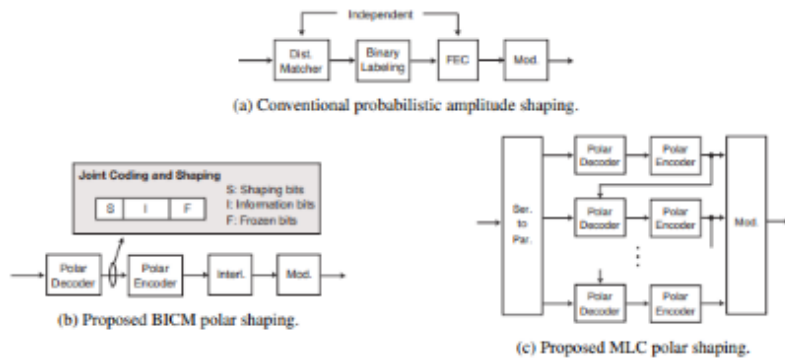

Sparse Blind Deconvolution for Distributed Radar Autofocus Imaging

Citation: Mansour, H., Liu, D., Kamilov, U., Boufounos, P.T., "Sparse Blind Deconvolution for Distributed Radar Autofocus Imaging", *IEEE Transactions on Image Processing*, DOI: 10.1109/TCI.2018.2875375, Vol. 4, No. 4, pp. 537-551, December 2018.

Contacts: Hassan Mansour, Dehong Liu, Petros T. Boufounos

A common problem that arises in radar imaging systems, especially those mounted on mobile platforms, is antenna position ambiguity. Approaches to resolve this ambiguity and correct position errors are generally known as radar autofocus. Common techniques that attempt to resolve the antenna ambiguity general by assume an unknown gain and phase error afflicting the radar

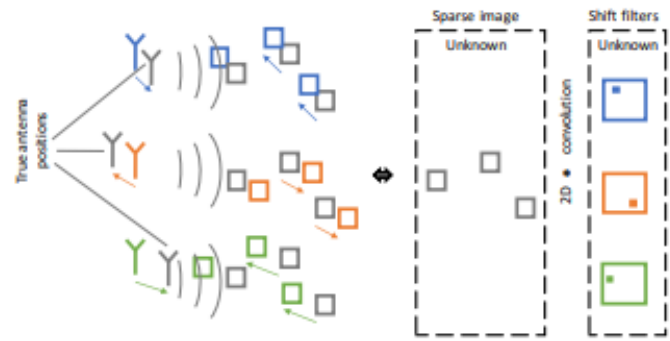

measurements. However, ensuring identifiability and tractability of the unknown error imposes strict restrictions on the allowable antenna perturbations. Furthermore, these techniques are often not applicable in near-field imaging, where mapping the position ambiguity to phase errors breaks down.

High-Resolution Lidar Using Random Demodulation

Citation: Boufounos, P.T., "High-Resolution Lidar Using Random Demodulation", *IEEE International Conference on Image Processing (ICIP)*, DOI: 10.1109/ICIP.2018.8451424, October 2018.

Contacts: Petros T. Boufounos

Recently emerging applications, such as autonomous navigation, mapping, and home entertainment, have increased the demand for inexpensive and high quality depth

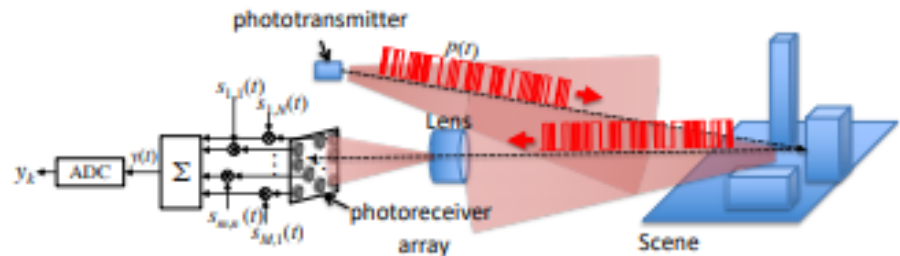

sensing. In this paper we fundamentally re-examine the problem, considering recent advances in photoelectric devices, increased availability of fast electronics, reduced computation cost, and developments in sensing theory. Our main contribution is a real-time hardware architecture for time-of-flight (tof) depth sensors that exploits random modulation to significantly reduce the acquisition burden. The proposed design is able to acquire compressive, critical, or redundant measurements, without requiring any hardware modifications, at the expense of small reduction in the system frame rate. The architecture we propose is sufficiently flexible to be operable in a variety of conditions and with a variety of reconstruction algorithms.

Machine-Learning Based Digital Doherty Power Amplifier

Citation: Ma, R.; Benosman, M.; Manjunatha, K.; Komatsuszaki, Y.; Shinjo, S.; Teo, K.H.; Orlik, P.V., “Machine-Learning Based Digital Doherty Power Amplifier”, *IEEE International Symposium on Radio Frequency Integration Technology (RFIT)*, DOI: 10.1109/RFIT.2018.8524126, August 2018.

Contacts: Rui Ma, Mouhacine Benosman, Philip Orlik, Koon Hoo Teo

This paper reports a new architecture of power amplifiers (PA), for which machine learning is applied in real-time to adaptively optimize PA performance. For varying input stimuli such as carrier frequency, bandwidth and power level, developed algorithms can intelligently optimize parameters including bias voltages, input signal phases and power

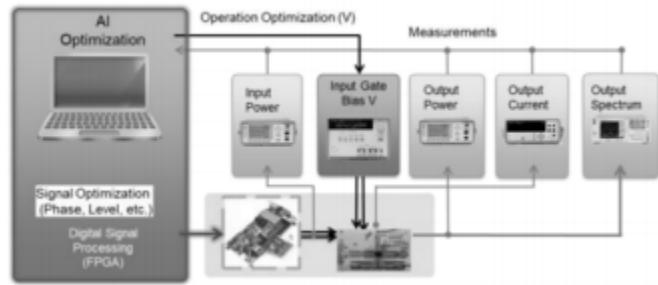

splitting ratios based on a user-defined cost function. Our demonstrator of a wideband GaN Digital Doherty PA achieves significant performance enhancement from 3.0-3.8 GHz, in particular, at high back-off power with approximately 3dB more Gain and 20% higher efficiency compared with analog counterpart. To the authors best knowledge, this is the first reported work of model-free machine learning applied for Doherty PA control.

Anomaly Detection in Manufacturing Systems Using Structured Neural Networks

Citation: Liu, J.; Guo, J.; Orlik, P.V.; Shibata, M.; Nakahara, D.; Mii, S.; Takac, M., “Anomaly Detection in Manufacturing Systems Using Structured Neural Networks”, *IEEE World Congress on Intelligent Control and Automation*, DOI: 10.1109/WCICA.2018.8630692, pp. 175-180, July 2018.

Contacts: Jianlin Guo, Philip Orlik

This paper proposes innovative anomaly detection technologies for manufacturing systems. We combine an event ordering relationship based structuring technique with deep neural networks to develop structured neural networks for anomaly detection.

The event ordering relationship based neural network structuring process is performed before neural network training process and determines important neuron connections and weight initialization. It

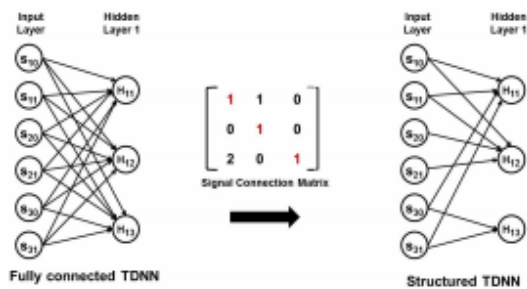

reduces the complexity of the neural networks and can improve anomaly detection accuracy. The structured time delay neural network (TDNN) is introduced for anomaly detection via supervised learning. To detect anomalies through unsupervised learning, we propose a structured autoencoder. The proposed structured neural networks outperform the unstructured neural networks in terms of anomaly detection accuracy and can reduce test error by 20%.

Frequency Noise Reduction of Integrated Laser Source with On-Chip Optical Feedback

Citation: Song, B.; Kojima, K.; Pina, S.; Koike-Akino, T.; Wang, B.; Klamkin, J., "Frequency Noise Reduction of Integrated Laser Source with On-Chip Optical Feedback", *Integrated Photonics Research, Silicon and Nano Photonics (IPR)*, DOI: 10.1364/IPRSN.2017.ITu1A.4, July 2017.

Contacts: Keisuke Kojima, Toshiaki Koike-Akino, Bingnan Wang

Integrated indium phosphide distributed-Bragg-reflector lasers with and without on-chip optical feedback are reported. The measured linewidth for the laser with coherent optical feedback is approximately 800 kHz, demonstrating an order of magnitude reduction.

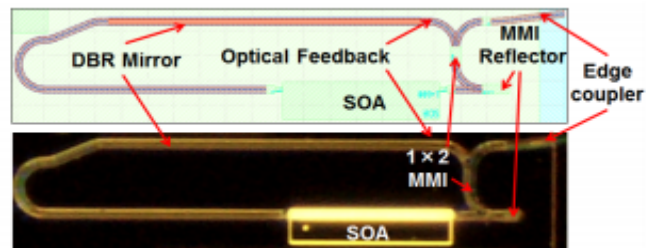

Remaining Useful Life Estimation of Batteries using Dirichlet Process with Variational Bayes Inference

Citation: Pajovic, M., Orlik, P.V., Wada, T., "Remaining Useful Life Estimation of Batteries using Dirichlet Process with Variational Bayes Inference", *Annual Conference of IEEE Industrial Electronics Society (IECON)*, DOI: 10.1109/IECON.2018.8592767, October 2018.

Contacts: Milutin Pajovic, Philip Orlik

Rechargeable batteries supply numerous devices with electric power and are critical part in a variety of applications. While estimation of battery's state of charge (SoC), state of health (SoH) and state of power (SoP) have been in research focus in the past years, prediction of battery degradation has recently started to gain interest. An accurate prediction of the remaining number of charge and discharge cycles a battery can undergo before it can no longer hold charge and is declared dead, is directly related to making timely decision as to when a battery should be replaced so that power interruption of the system it supplies power to is avoided. A methodology for inferring probability distribution of the remaining number of charge-discharge cycles of a battery, based on training dataset containing measured discharge voltage waveforms of one or more batteries of similar type, is presented in this paper. The methodology strongly draws on modeling discharge voltage waveforms using Dirichlet Process Mixture Model framework and performs approximate inference using variational Bayes approach. The experimental results corroborate that the proposed method is able to provide useful predictions of the remaining useful life of a battery in early stages of its life.

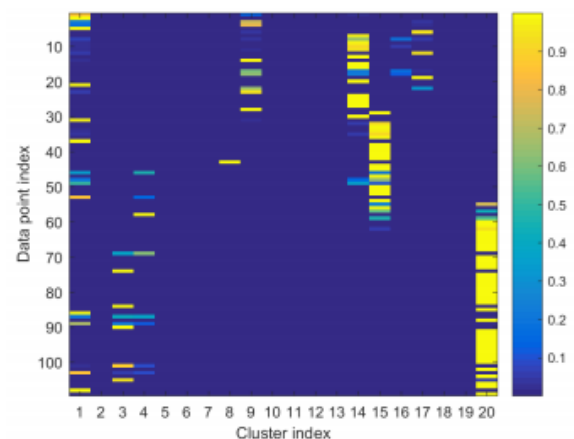

Control & Dynamical Systems

The Control and Dynamical Systems Group has expertise in multivariable, nonlinear, optimal & model predictive control theory, nonlinear estimation, nonlinear dynamical systems, mechanical design, thermo-fluid system dynamics, laser processing and sensing, and rapid prototyping. The business drivers for this R&D program are twofold. First, control of mechanical and electrical systems is central to many areas of Mitsubishi Electric's business. Second, with the increasing power and decreasing cost of embedded computation and sensing technologies, there is the opportunity for innovation and synergy among researchers in this group and other researchers in MERL's other groups whose strengths include signal processing, computer and information technology.

Automatic control systems take real-time measurements of a system under control, process the information with a control algorithm, and apply the results of the calculation back to the system under control via actuators. Feedforward, feedback, and estimation are the central concepts. MERL's research focuses on development of new control algorithms that provide higher performance than the state-of-the-art. Recent results include more energy efficient air conditioners and servomotors, path planning and steering control for autonomous vehicles, more precise laser processing systems, improved GNSS position estimation, statistical estimation for sensor fusion, and satellite station keeping. MERL also conducts fundamental research to develop new control theory for general-purpose use, with a strong focus on model predictive control and nonlinear state and parameter estimation.

A dynamical system is one described by differential or difference equations. MERL's interest is to improve the performance of MELCO products and technology through the application of nonlinear dynamical systems theory. Applied research interests include indoor and outdoor airflow, traffic control, optimal transport, mixing in fluids and thermo-fluid systems dynamics, and the design of minimum-fuel trajectories for space probes, all of which exploit nonlinearity and chaos in highly creative and deeply mathematical ways.

Recent Research

Data-Driven Estimation of Reachable and Invariant Sets for Unmodeled Systems via ...	74
Noise-Statistics Learning of Automotive-Grade Sensors Using Adaptive Marginalized ...	74
Positive Invariant Sets for Safe Integrated Vehicle Motion Planning and Control.....	75
Reduced-order modeling of fully turbulent buoyancy-driven flows using Green's function ...	75
Assignment and Control of Two-Tiered Vehicle Traffic.....	76
Motion Planning of Autonomous Road Vehicles by Particle Filtering	76
An approximate high gain observer for speed-sensorless estimation of induction motors.....	77
Projected Preconditioning within a Block-Sparse Active-Set Method for MPC	77
Data-driven output feedback optimal control for a class of nonlinear systems via ...	78
Embedded Optimization Algorithms for Steering in Autonomous Vehicles based on ...	78
Adjoint-Based Optimization of Displacement Ventilation Flow	79
Reachability-based Decision Making for City Driving	79
GNSS Ambiguity Resolution by Adaptive Mixture Kalman Filter.....	80
Station keeping and momentum management of low-thrust satellites using MPC	80

Data-Driven Estimation of Reachable and Invariant Sets for Unmodeled Systems via Active Learning

- Citation: Chakrabarty, A.; Raghunathan, A.U.; Di Cairano, S.; Danielson, C., “Data-Driven Estimation of Reachable and Invariant Sets for Unmodeled Systems via Active Learning”, *IEEE Conference on Decision and Control (CDC)*, DOI: 10.1109/CDC.2018.8619646, December 2018.
- Contacts: Ankush Chakrabarty, Arvind U. Raghunathan, Stefano Di Cairano, Claus Danielson

Ensuring control performance with state and input constraints is facilitated by the understanding of reachable and invariant sets. While exploiting dynamical models has provided many set-based algorithms for constructing these sets, set-based methods typically do not scale well, or rely heavily on model accuracy or structure. In contrast, it is relatively simple to generate state trajectories in a data-driven manner by numerically simulating complex systems from initial conditions sampled from within an admissible state space, even if the underlying dynamics are completely unknown. These samples can then be leveraged for reachable/invariant set estimation via machine learning, although the learning performance is strongly linked to the sampling pattern. In this paper, active learning is employed to intelligently select batches of samples that are most informative and least redundant to previously labeled samples via submodular maximization. Selective sampling reduces the number of numerical simulations required for constructing the invariant set estimator, thereby enhancing scalability to higher-dimensional state spaces.

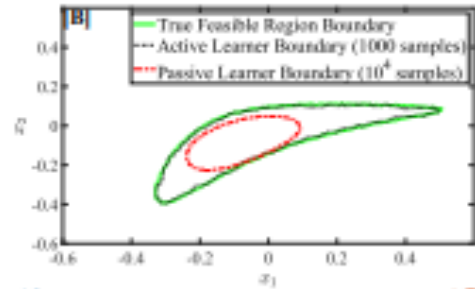

Noise-Statistics Learning of Automotive-Grade Sensors Using Adaptive Marginalized Particle Filtering

- Citation: Berntorp, K.; Di Cairano, S., “Noise-Statistics Learning of Automotive-Grade Sensors Using Adaptive Marginalized Particle Filtering”, *Journal of Dynamic Systems, Measurement, and Control*, DOI: 10.1115/1.4042673, vol. 141, December 2018.
- Contacts: Karl Bertorp, Stefano Di Cairano

This paper presents a method for real-time identification of sensor statistics especially aimed for low-cost automotive-grade sensors. Based on recent developments in adaptive particle filtering and under the assumption of Gaussian distributed noise, our method identifies the slowly time-varying sensor offsets and variances jointly with the vehicle state, and it extends to banked roads. While the method is primarily focused on learning the noise characteristics of the sensors, it also produces an estimate of the vehicle state. This can then be used in driver-assistance systems, either as a direct input to the control system, or indirectly to aid other sensor-fusion methods.

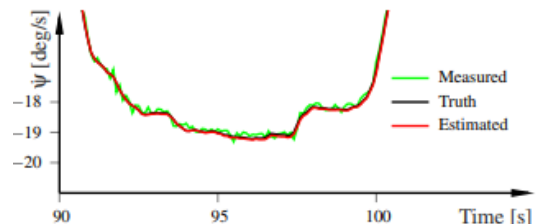

Positive Invariant Sets for Safe Integrated Vehicle Motion Planning and Control

Citation: Berntorp, K.; Danielson, C.; Weiss, A.; Di Cairano, S., “Positive Invariant Sets for Safe Integrated Vehicle Motion Planning and Control”, *IEEE Annual Conference on Decision and Control (CDC)*, DOI: 10.1109/CDC.2018.8619458, December 2018

Contacts: Karl Berntorp, Claus Danielson, Avishai Weiss, Stefano Di Cairano

This paper describes a method for real-time integrated motion planning and control of autonomous vehicles. Our method leverages feedback control, positive invariant sets, and equilibrium trajectories of the closed-loop system to guarantee collision-free closed-loop trajectory tracking. Our method jointly steers the vehicle to a target region and controls the velocity while satisfying constraints associated with the future motion of the obstacles with respect to the vehicle.

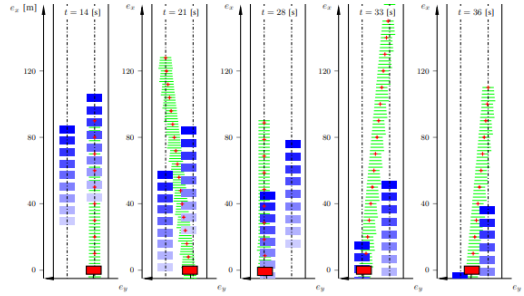

We develop a receding-horizon implementation and verify the method in a simulated road scenario. The results show that our method generates safe dynamically feasible trajectories while accounting for obstacles in the environment and modeling errors.

Reduced-order modeling of fully turbulent buoyancy-driven flows using the Green's function method

Citation: Khodkar, A.; Hassanzadeh, P.; Nabi, S.; Grover, P., “Reduced-order modeling of fully turbulent buoyancy-driven flows using the Green's function method”, *Physical Review Fluids*, DOI: 10.1103/PhysRevFluids.4.013801, vol. 4, December 2018.

Contacts: Saleh Nabi, Piyush Grover

A One-Dimensional (1D) Reduced-Order Model (ROM) has been developed for a 3D Rayleigh Benard convection system in the turbulent regime with Rayleigh number $Ra = 106$. The state vector of the 1D ROM is horizontally averaged temperature. Using the Green's Function (GRF) method, which involves applying many localized, weak forcings to the system one at a time and calculating the responses using long-time averaged Direct Numerical Simulations (DNS), the system's Linear Response Function (LRF) has been computed. Another matrix, called the Eddy Flux Matrix (EFM), that relates changes in the divergence of vertical eddy heat fluxes to changes in the state vector, has also been calculated. Using various tests, it is shown that the LRF and EFM can accurately predict the time-mean responses of temperature and eddy heat flux to external forcings, and that the LRF can well predict the forcing needed to change the mean flow in a specified way (inverse problem).

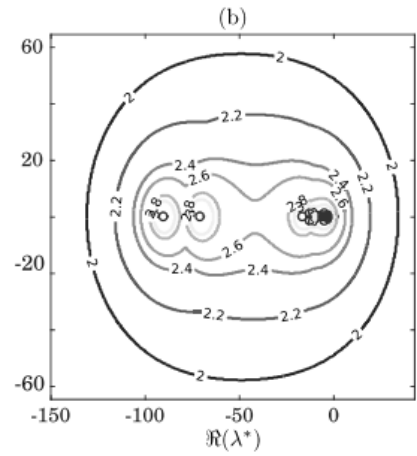

Assignment and Control of Two-Tiered Vehicle Traffic

Citation: Nilsson, G.; Grover, P.; Kalabic, U., “Assignment and Control of Two-Tiered Vehicle Traffic”, *IEEE Conference on Decision and Control (CDC)*, DOI: 10.1109/CDC.2018.8619411, December 2018.

Contacts: Piyush Grover, Uros Kalabic

This work considers the assignment of vehicle traffic consisting of both individual, opportunistic vehicles and a cooperative fleet of vehicles. The first set of vehicles seek a user-optimal policy and the second set seeks a fleet-optimal policy. We provide explicit sufficient conditions for the existence and uniqueness of a Nash equilibrium at which both policies are satisfied. We also propose two different algorithms to determine the equilibrium, one centralized and one decentralized. Furthermore, we present a control scheme to attain such an equilibrium in a dynamical network flow. An example is considered showing the workings of our scheme and numerical results are presented.

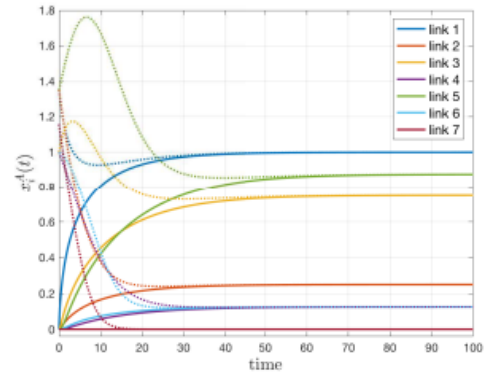

Motion Planning of Autonomous Road Vehicles by Particle Filtering

Citation: Berntorp, K.; Hoang, T.; Di Cairano, S., “Motion Planning of Autonomous Road Vehicles by Particle Filtering”, *IEEE Transactions on Intelligent Vehicles*, DOI: DOI: 10.1109/TIV.2019.2904394, vol. 4, pp. 197-210, December 2018.

Contacts: Karl Berntorp, Stefano Di Cairano

This paper describes a probabilistic method for real-time decision making and motion planning for autonomous vehicles. Our approach relies on that driving on road networks implies a priori defined requirements that the motion planner should satisfy. Starting from an initial state of the vehicle, a map, the obstacles in the region of interest, and a goal region, we formulate the motion-planning problem as a nonlinear nonGaussian estimation problem, which we solve using particle filtering. We assign probabilities to the generated trajectories according to their likelihood of obeying the driving requirements. Decision making and collision avoidance is naturally integrated in the approach. We develop a receding-horizon implementation and verify the method in simulated real road scenarios and in an experimental validation using a scaled mobile robot setup with car-like dynamics. The results show that the method generates dynamically feasible trajectories for a number of scenarios, such as collision avoidance, overtaking, and traffic-jam scenarios. In addition, the computation times and memory requirements indicate that the method is suitable for real-time implementation.

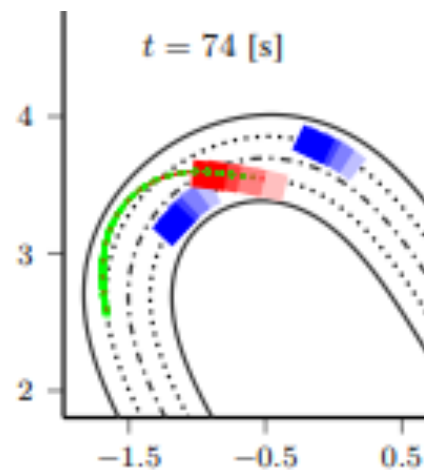

An approximate high gain observer for speed-sensorless estimation of induction motors

Citation: Wang, Y.; Zhou, L.; Bortoff, S.A.; Satake, A.; Furutani, S., “An approximate high gain observer for speed-sensorless estimation of induction motors”, *IEEE/CAA Journal of Automatica Sinica*, DOI: 10.1109/JAS.2018.7511252, vol. 6, pp. 53-63, December 2018

Contacts: Yebin Wang, Scott Bortoff

Rotor speed estimation for induction motors is a key problem in speed-sensorless motor drives. This paper performs nonlinear high gain observer design based on the full-order model of the induction motor. Such an effort appears nontrivial due to the fact that the full model at best admits locally a non-triangular observable form (NTOF), and its analytical representation in the NTOF can not be obtained. This paper proposes an approximate high gain estimation algorithm, which enjoys a constructive design, ease of tuning, and improved speed estimation and tracking performance. Experiments demonstrate the effectiveness of the proposed algorithm.

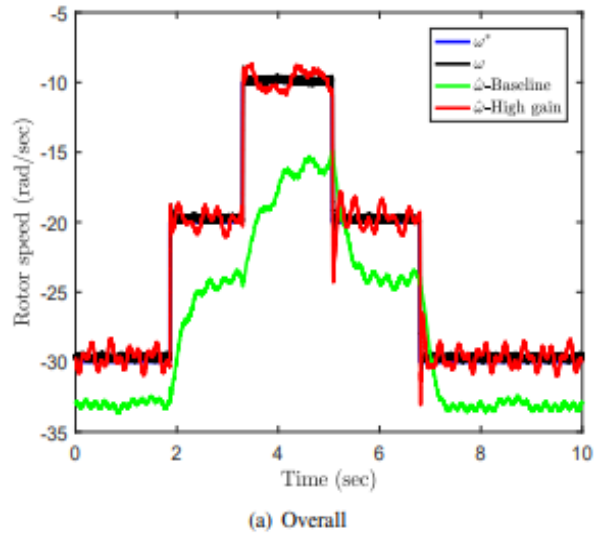

Projected Preconditioning within a Block-Sparse Active-Set Method for MPC

Citation: Quirynen, R.; Knyazev, A.; Di Cairano, S., “Projected Preconditioning within a Block-Sparse Active-Set Method for MPC”, *IFAC Conference on Nonlinear Model Predictive Control (NMPC)*, DOI: 10.1016/j.ifacol.2018.10.170, vol. 51, pp. 28-34, August 2018.

Contacts: Rien Quirynen, Stefano Di Cairano

Model predictive control (MPC) often requires solving an optimal control structured quadratic program (QP), possibly based on an online linearization at each sampling instant. Block-tridiagonal preconditioners have been proposed, combined with the minimal residual

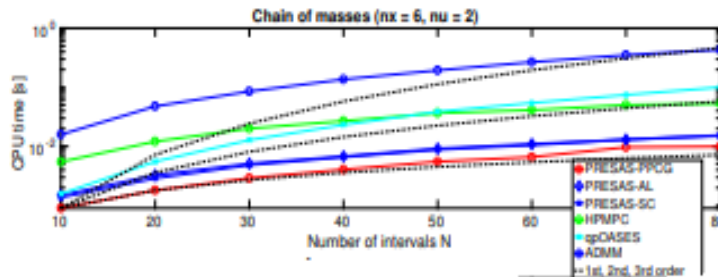

(MINRES) method, to result in a simple but efficient implementation of a sparse active set strategy for fast MPC. This paper presents an improved variant of this PRESAS algorithm, by using a projected preconditioned conjugate gradient (PPCG) method. Based on a standalone C code implementation and using an ARM Cortex-A7 processor, we illustrate the performance of the proposed solver against the current state of the art for embedded predictive control.

Data-driven output feedback optimal control for a class of nonlinear systems via adaptive dynamic programming approach: Part I: Algorithms

Citation: Wang, Y., “Data-driven output feedback optimal control for a class of nonlinear systems via adaptive dynamic programming approach: Part I: Algorithms”, *Chinese Control Conference (CCC)*, DOI: 10.23919/ChiCC.2018.8483373, pp. 2926-2932, July 2018.
Contacts: Yebin Wang

This work investigates data-driven output feedback optimal control design for a class of nonlinear systems. It proposes to parameterize all admissible output feedback optimal control policies over accessible signals (system output and its time derivatives). In the case that system state can be parameterized as functions of accessible signals, then the value function and control policy can be parameterized over accessible signals, which allow Approximate/adaptive dynamic programming (ADP) to be driven by accessible data. For a special case, where system state, value function and control policy can be linearly parameterized over a finite functional space over accessible signals, the policy iteration algorithm (PI) of ADP is reduced to solve a system of linear equations.

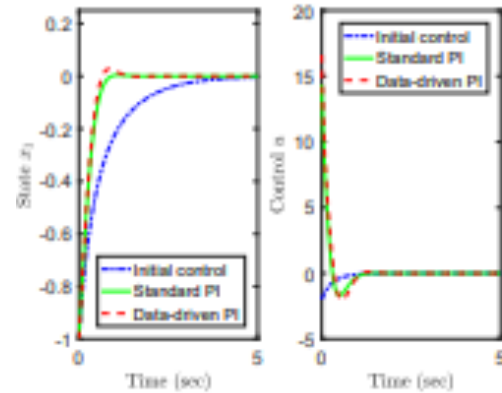

Embedded Optimization Algorithms for Steering in Autonomous Vehicles based on Nonlinear Model Predictive Control

Citation: Quirynen, R.; Berntorp, K.; Di Cairano, S., “Embedded Optimization Algorithms for Steering in Autonomous Vehicles based on Nonlinear Model Predictive Control”, *American Control Conference (ACC)*, DOI: 10.23919/ACC.2018.8431260, pp. 3251-3256, June 2018.
Contacts: Rien Quirynen, Karl Berntorp, Stefano Di Cairano

Steering control for autonomous vehicles on slippery road conditions, such as on snow or ice, results in a highly nonlinear and therefore challenging online control problem, for which nonlinear model predictive control (NMPC) schemes have shown to be a promising approach. NMPC allows to deal with the nonlinear vehicle dynamics as well as the system limitations and geometric constraints in a rather natural way, given a desired trajectory that can be provided by a supervisory algorithm for path planning. Our aim is to study the real-time feasibility of NMPC-based steering control on an embedded computer and the importance of the appropriate vehicle model selection, the optimization solver choice and control horizon length.

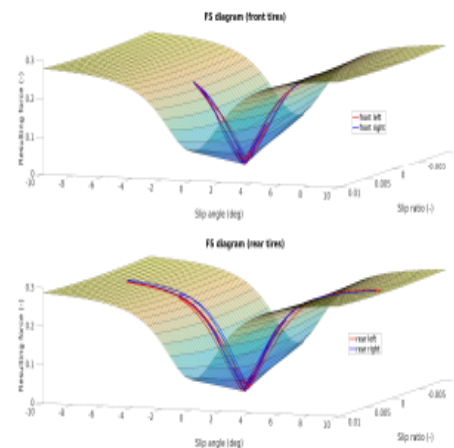

Adjoint-Based Optimization of Displacement Ventilation Flow

Citation: Nabi, S.; Grover, P.; Caulfield, C.C., “Adjoint-Based Optimization of Displacement Ventilation Flow”, *Building and Environment*, DOI: 10.1016/j.buildenv.2017.07.030, vol. 124, pp. 342-356, July 2017

Contacts: Saleh Nabi, Piyush Grover

We demonstrate the use of the 'Direct-Adjoint-Looping method' for the identification of optimal buoyancy-driven ventilation flows governed by Boussinesq equations. We use the incompressible Reynolds averaged Navier-Stokes (RANS) equations, derive the corresponding adjoint equations and solve the resulting sensitivity equations with respect to inlet conditions. We focus on a displacement ventilation scenario with a steady plume due to a line source. Subject to an enthalpy flux constraint on the incoming flow, we identify boundary conditions leading to 'optimal' temperature distributions in the occupied zone. Our results show that depending on the scaled volume and momentum flux of the inlet flow, qualitatively different flow regimes may be obtained.

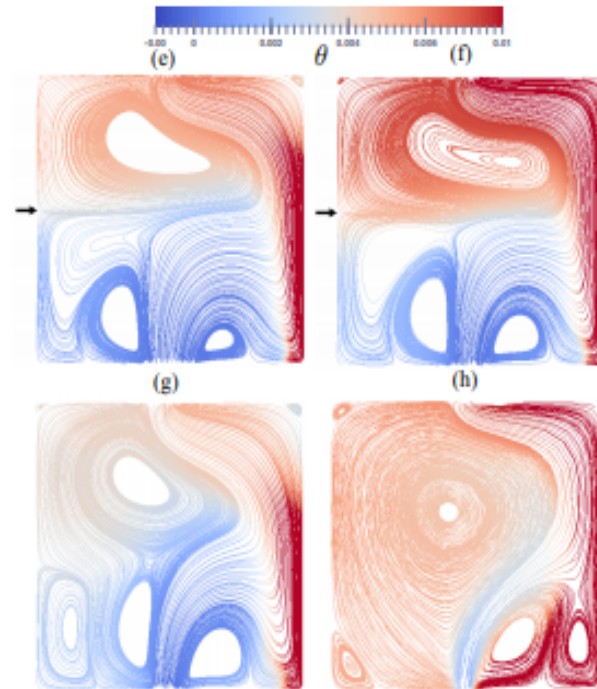

Reachability-based Decision Making for City Driving

Citation: Ahn, H.; Berntorp, K.; Di Cairano, S., “Reachability-based Decision Making for City Driving”, *American Control Conference (ACC)*, DOI: 10.23919/ACC.2018.8431819, pp. 3203-3208, June 2018.

Contacts: Heejin Ahn, Karl Bernorp, Stefano Di Cairano

This paper presents the design of a discrete decision-making algorithm for vehicles with advanced driver-assistance and automated features. We model the system as a hybrid automaton, where transitions between discrete modes in the automaton correspond to driving mode decisions, and develop a method to determine the timing of mode transitions based on backward and forward reachable sets. The algorithm can be used either as a stand-alone component or as a method to guide an underlying motion planner to safe reference trajectories. Under certain assumptions, the algorithm guarantees safety and liveness, which can be validated through computer simulations on a city driving scenario that requires going through multiple discrete modes and includes several surrounding moving obstacles.

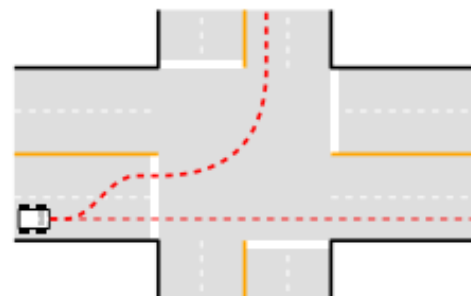

GNSS Ambiguity Resolution by Adaptive Mixture Kalman Filter

Citation: Berntorp, K.; Weiss, A.; Di Cairano, S., “GNSS Ambiguity Resolution by Adaptive Mixture Kalman Filter”, *International Conference on Information Fusion (FUSION)*, DOI: 10.23919/ICIF.2018.8455617, July 2018.
Contacts: Karl Berntorp, Avishai Weiss, Stefano Di Cairano

The precision of global navigation satellite systems (GNSSs) relies heavily on accurate carrier phase ambiguity resolution. The ambiguities are known to take integer values, but the set of ambiguity values is unbounded. We propose a mixture Kalman filter solution to GNSS ambiguity resolution. By marginalizing out the set of ambiguities and exploiting a likelihood proposal for generating the ambiguities, we can bound the possible values to a tight and dense set of integers, which allows for extracting the integer solution as a maximum likelihood estimate from a mixture Kalman filter. We verify the efficacy of the approach in simulation including a comparison with a well-known integer least-squares based method. The results indicate that our proposed switched mixture Kalman filter repeatedly finds the correct integers in cases where the other method fails.

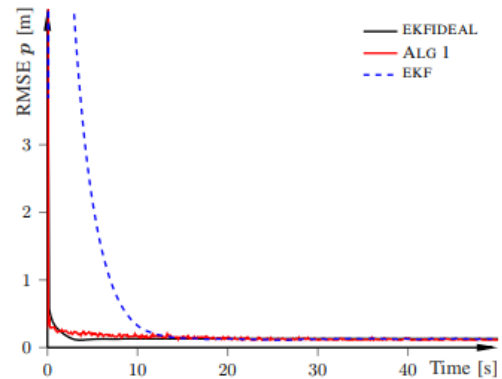

Station keeping and momentum management of low-thrust satellites using MPC

Citation: Weiss, A.; Kalabić, U.; Di Cairano, S., “Station keeping and momentum management of low-thrust satellites using MPC”, *Aerospace Science and Technology*, DOI: 10.1016/j.ast.2018.02.014, vol. 76, pp. 229-241, May, 2018.
Contacts: Avishai Weiss, Uros Kalabic, Stefano Di Cairano

This work proposes a Model Predictive Control (MPC) policy for simultaneous station keeping and momentum management of a low-thrust nadir-pointing satellite in geostationary orbit around the Earth. The satellite is equipped with six electrically powered thrusters and three axisymmetric reaction wheels, which must be coordinated to control the satellite orbital position and, concurrently, unload the wheels’ stored angular momentum. The MPC policy enforces constraints that maintain the satellite in a tight latitude and longitude window and in a tight nadir-pointing attitude configuration, while minimizing the delta-v provided by the thrusters. The MPC policy exploits a prediction model of the environmental disturbance forces in order to significantly reduce the delta-v required for station keeping, and enforces constraints determined by the thruster configuration to select control forces and torques that can be generated by the propulsion system. Numerical simulations of the control policy in closed-loop with the satellite nonlinear dynamics under high-precision orbit propagation provided by Systems Tool Kit (STK) that validate the performance of the proposed design in terms of thruster usage and constraint enforcement are presented.

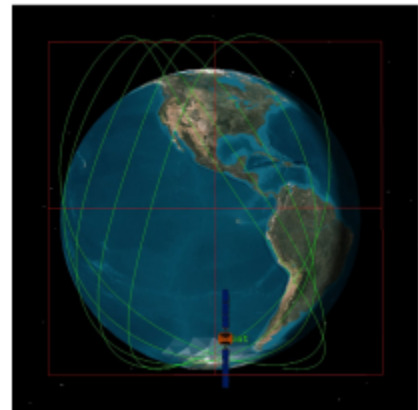

Multi-Physical Systems & Devices

Multi-Physical Systems & Devices cover researches on multi-physical modeling, simulation and model-based design of dynamic systems, advanced machines and devices. This research serves as a foundation for other technologies, such as signal processing, control, optimization, and artificial intelligence. We investigate modeling fundamentals including mathematical formulations of multi-physical dynamics, accurate models of complex systems via state-of-the-art modeling tools, fundamental principles and applied physics research, rapid simulations via model reduction and parallel solvers, and model-based design process for optimization of architecture, control and performance.

The “Systems” research focuses on the following areas: the development and application of new tools to model and simulate complex, heterogeneous systems; the creation of new multi-physical system designs (architectures) and performance metrics; the invention of new optimal control, coordinating control, and estimation algorithms; and the use of collaborative design tools and processes for future products. Target applications include model-based HVAC design, control and optimization; advanced assembly lines in factories; and digital twin systems for zero-energy buildings.

The “Devices” area emphasizes highly reliable wideband power amplifier technologies and new semiconductor devices; advanced motor modeling, fault detection and reliable predictive maintenance; electro-magnetic analysis for non-contact sensing; first-principles analysis of condensed matter physics for new material design; and technologies for superconductor and magnet applications.

Recent Research

Tube-fin Heat Exchanger Circuitry Optimization for Improved Performance Under	82
Coupled Simulation of a Room Air-conditioner with CFD Models for Indoor Environment.....	82
Using Baumgarte's Method for Index Reduction in Modelica.....	83
An Extended Luenberger Observer for HVAC Application using FMI.....	83
... Approximate Momentum Equations in Dynamic Models of Vapor Compression Systems....	84
Numerical Modeling of Fin-and-Tube Condenser with Wet-wall De-superheating	84
Object-Oriented Modeling and Control of Delta Robots.....	85
Power Optimizing Control of Multi-Zone Heat Pumps.....	85
... Control of Multi-Zone Buildings with Ventilation and VRF systems in Cooling Mode.....	86
... transient characteristics of an air source heat pump with vapor injection during	86
... Coordinated Control of an Air-Source Heat Pump and Hydronic Radiant Heating System....	87
Metamaterial Absorber for THz Polarimetric Sensing	87
... thermal radiative devices and ... near-field negative electroluminescent cooling	88
... Incorporating p-Diamond Back-barriers and Cap-layers into AlGaIn/GaN HEMTs	88

Tube-fin Heat Exchanger Circuitry Optimization for Improved Performance Under Frosting Conditions

Citation: Li, Z.; Qiao, H.; Aute, V., “Tube-fin Heat Exchanger Circuitry Optimization for Improved Performance Under Frosting Conditions”, *International Modelica Conference*, DOI: 10.3384/ecp19157259, March 2019.
 Contacts: Hongtao Qiao

Frost accumulation on tube-fin heat exchanger leads to reduction in evaporator capacity and deteriorates cycle efficiency. The conventional counter-flow heat exchanger (HX) circuitry has the disadvantage that more frost tends to accumulate in the first few banks exposed to the incoming air. This frost concentration makes the air side flow resistance increase rapidly, thus reduces the air flow rate and evaporator capacity under constant fan power. In this paper, a novel integer permutation based Genetic Algorithm is used to obtain optimal circuitry design with improved HX performance under frosting conditions. A dynamic HX model with the capability to account for non-uniform frost growth on a fan-supplied coil is used to assess the performance of optimal circuitry. A case study shows that our circuitry design approach yields better circuitry with larger HX capacity, more uniform frost distribution, less air flow path blockage, and thus longer evaporator operation time between defrost cycles.

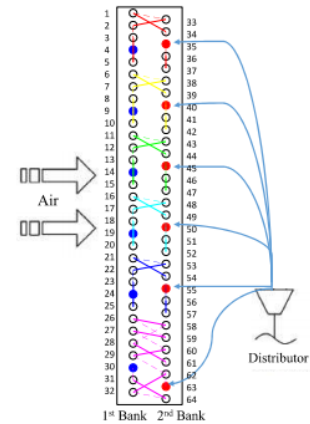

Coupled Simulation of a Room Air-conditioner with CFD Models for Indoor Environment

Citation: Qiao, H.; Nabi, S.; Han, X.; Laughman, C.R., “Coupled Simulation of a Room Air-conditioner with CFD Models for Indoor Environment”, *International Modelica Conference*, March 2019.
 Contacts: Hongtao Qiao, Saleh Nabi, Christopher R. Laughman

Coupled simulation of building energy systems (BES) and computation fluid dynamics (CFD) often focuses on the integration of air handlers with the indoor environment, and does not incorporate vapor compression systems into the analysis, yielding inaccurate prediction of building energy consumption. This paper presents a coupled simulation to explore the pull-down performance of a room air conditioning system. Numerical simulations demonstrate that both vane angle and airflow mode exhibit pronounced impact on the pull-down time. Meanwhile, the well-mixed assumption that most of building energy simulation programs are built upon exhibits drastically different dynamic characteristics compared to the detailed CFD model, suggesting that neglecting non-uniform air flow and temperature distributions in buildings might lead to significant errors in control design.

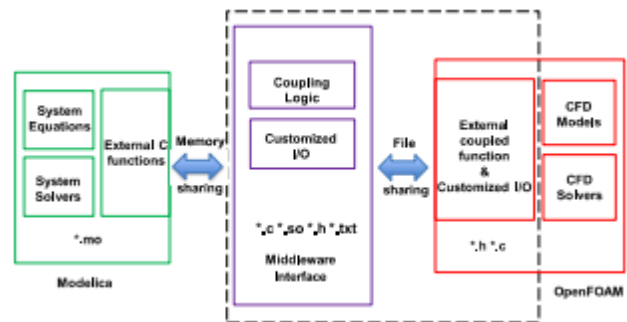

Using Baumgarte's Method for Index Reduction in Modelica

Citation: Bortoff, S.A., “Using Baumgarte's Method for Index Reduction in Modelica”, *International Modelica Conference*, March 2019.

Contacts: Scott A. Bortoff

We show by example how Baumgarte’s method can be used in a Modelica model to reduce the differential algebraic equation index prior to compilation. This has advantages for some constrained mechanical systems especially those with closed-chain kinematics, including improved initialization and enabling model-based control system design. We derive models for a simple pendulum, a delta robot and for elevator cable sway as case studies. The models are used for simulation and also for dynamic analysis and to design and realize feedback controllers.

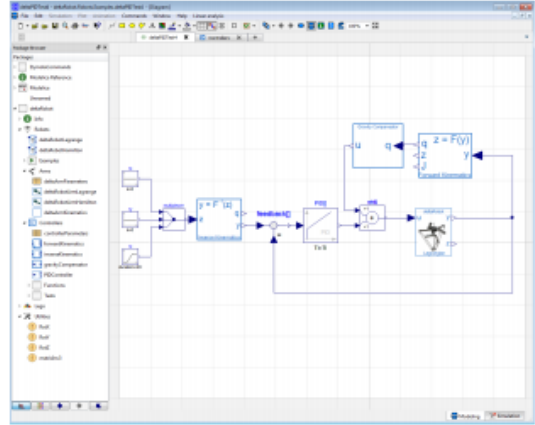

An Extended Luenberger Observer for HVAC Application using FMI

Citation: Bortoff, S.A.; Laughman, C.R., “An Extended Luenberger Observer for HVAC Application using FMI”, *International Modelica Conference*, March 2019

Contacts: Scott A. Bortoff, Christopher R. Laughman

In this paper we show how a Functional Mockup Unit (FMU) may be used for the realization of an Extended Luenberger Observer (ELO), which may be considered the deterministic version of an Extended Kalman Filter (EKF). The ELO has advantages over an EKF in some situations, such as lower computational burden and improved convergence. Nonlinear observers, such as those that make use of changes of coordinates to linearize, or approximately linearize the estimate error, are continuous-time dynamical systems that use so-called output injection to modify the dynamics of a model. Output injection provides a similar feedback effect as the correction step of an EKF. However, nonlinear output injection is a slightly different use case because the ELO is a continuous time object. It is realized by feedback around a modelsharing type of continuous time FMU, in contrast with the algorithmic realization of a discrete-time EKF, which uses the co-simulation form of FMU. We illustrate the design and realization of an ELO for a building HVAC example, in which we estimate unmeasured heat flows and unmeasured boundary conditions for use in a building “digital twin.” We also make some remarks about model reduction and the challenges in realizing a conventional EKF for these types of models.

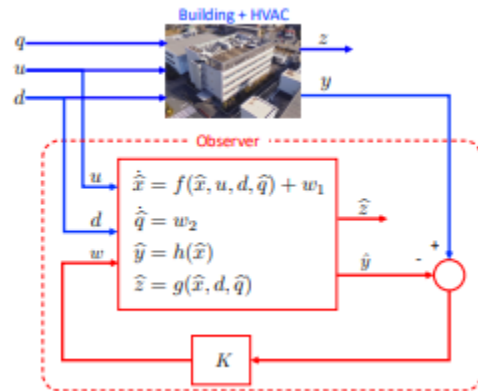

Comparison of Approximate Momentum Equations in Dynamic Models of Vapor Compression Systems

Citation: Qiao, H.; Laughman, C.R., “Comparison of Approximate Momentum Equations in Dynamic Models of Vapor Compression Systems”, *International Heat Transfer Conference*, August 2018.

Contacts: Hongtao Qiao, Christopher R. Laughman

In this paper, we formulate refrigerant circuitry design as a binary constrained optimization problem. We use CoilDesigner, a simulation and design tool of air to refrigerant heat exchangers, in order to simulate the performance of different refrigerant circuitry designs and use Derivative-free optimization (DFO) algorithms. We compare four mixed-integer constrained DFO solvers and one box-bounded DFO solver and evaluate their ability to solve a difficult industrially relevant problem. We demonstrate that the proposed formulation is suitable for optimizing the circuitry configuration.

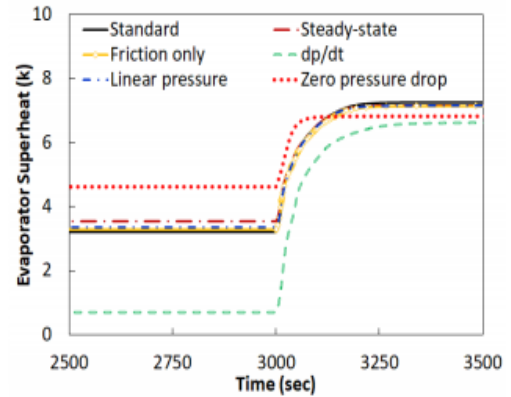

Numerical Modeling of Fin-and-Tube Condenser with Wet-wall De-superheating

Citation: Qiao, H.; Laughman, C.R., “Numerical Modeling of Fin-and-Tube Condenser with Wet-wall De-superheating”, *International Refrigeration and Air Conditioning Conference at Purdue*, August 2018.

Contacts: Hongtao Qiao, Christopher R. Laughman

Current heat exchanger simulation models typically divide the condenser into three regimes (desuperheating, twophase and subcooled) and assume that condensation does not start until the bulk refrigerant flow reaches a state of saturated vapor. However, plenty of experiments have verified that condensation can occur much earlier than that when the tube wall surface temperature drops below the dew point of refrigerant even though the bulk flow is still superheated. This phenomenon is called wet-wall desuperheating (also referred to as wetdesuperheating, or condensation from desuperheated vapor in some publications). Wet-wall desuperheating is rarely modelled in the extant heat exchanger simulations due to lack of understanding of its physical process. However, neglecting this important phenomenon may lead to substantial performance prediction errors. This paper proposes a new fin-and-tube condenser heat exchanger model in which the heat exchanger is divided into four regimes: dry-wall desuperheating, wet-wall desuperheating, two-phase condensation and subcooled. A tube-by-tube analysis is adopted to allow for the simulation of complex tube circuitries. Results show that wet-wall desuperheating always exists in the condenser with refrigerant vapor entering at the inlet, and neglecting the phenomenon can lead to significant prediction errors for heat exchanger performance.

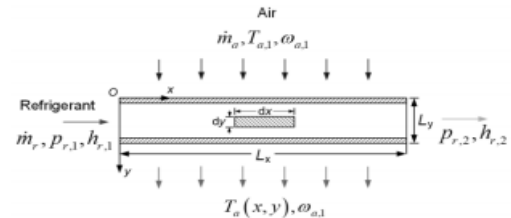

Object-Oriented Modeling and Control of Delta Robots

Citation: Bortoff, S.A., “Object-Oriented Modeling and Control of Delta Robots”, *IEEE Conference on Control Technology and Applications*, August 2018.
 Contacts: Scott A. Bortoff

In this paper we derive a dynamic model of the Delta robot that is well-suited to an object-oriented modeling framework. The approach uses an augmented Lagrangian or Hamiltonian formulation together with Baumgarte’s method of index reduction, and results in a singularity-free dynamic model that is well suited to dynamic analysis, control system synthesis and time-domain simulation. The object-oriented structure enables broad application to problems such as coordinated control and robotic assembly. We present several common control algorithms and conduct a dynamic analysis of the Delta robot that shows that the open-loop system is unstable for large volumes of the reachable workspace, which has fundamental implications on closed-loop performance.

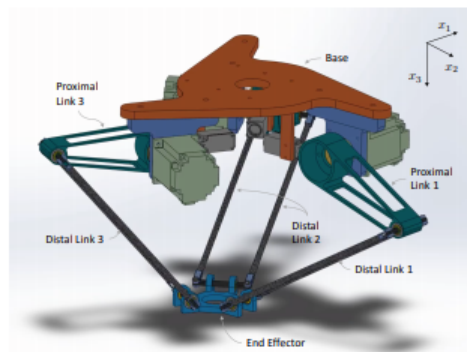

Power Optimizing Control of Multi-Zone Heat Pumps

Citation: Bortoff, S.A.; Burns, D.J.; Laughman, C.R.; Qiao, H.; Danielson, C.; Goldsmith, A.M.; Di Cairano, S., “Power Optimizing Control of Multi-Zone Heat Pumps”, *IEEE Conference on Control Technology and Applications*, August 2018.
 Contacts: Scott A. Bortoff, Daniel J. Burns, Christopher R. Laughman, Hongtao Qiao, Claus Danielson

We derive a power-optimizing output feedback controller for a multi-zone heat pump that (1) regulates individual zone temperatures, rejecting unknown heat load disturbances, (2) regulates condenser subcooling and (3) the compressor discharge temperature, and (4) minimizes electrical power consumption at steady-state operating conditions. The design is a cascade of a linear inner-loop and a nonlinear outer-loop.

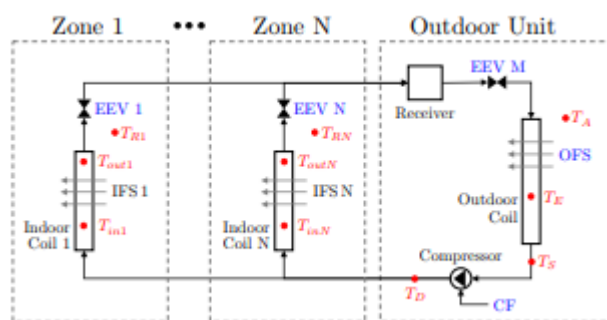

The inner-loop is designed for robust disturbance rejection using H-infinity loop-shaping methods. The outer-loop uses a model of compressor and fan power consumption and a gradient descent feedback to drive the system to its powerminimizing equilibrium for constant values of references and disturbances. The controller uses only temperature measurements for feedback; refrigerant pressure sensors, which are not present in many products for cost reasons, are not required. A proof of exponential stability is provided and preliminary experimental tests demonstrate satisfactory transient responses for a commercial multi-zone heat pump.

Integrated Control of Multi-Zone Buildings with Ventilation and VRF systems in Cooling Mode

Citation: Laughman, C.R.; Bortoff, S.A.; Qiao, H., “Integrated Control of Multi-Zone Buildings with Ventilation and VRF systems in Cooling Mode”, *Purdue High-Performance Buildings Conference*, July 2018.

Contacts: Christopher R. Laughman, Scott A. Bortoff, Hongtao Qiao

One common strategy for achieving reduced energy consumption and improved comfort in modern high-performance buildings involves the use of multiple interacting heating, cooling, and ventilation systems. Because tighter and more insulating building envelopes are often accompanied by a reduction in the capacity of the space conditioning systems, the limited

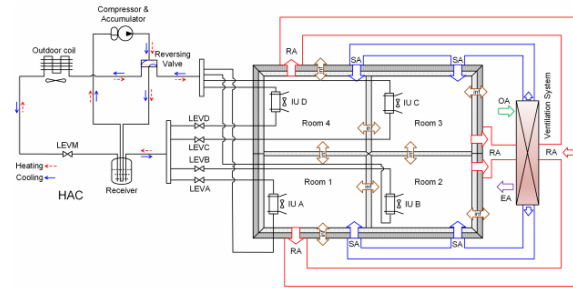

control authority of these smaller systems raises the importance of understanding dynamics and control in this built environment. We explore the use of model-based strategies for analyzing and controlling the behavior of a representative building incorporating both a multi-zone VRF system and a ventilation system. Analysis of the integrated system indicates that the subsystems interact dynamically, and that these dynamics must be considered during the design process.

Modeling of transient characteristics of an air source heat pump with vapor injection during reverse-cycle defrosting

Citation: Hongtao, Q.; Aute, V.; Radermacher, R., “Modeling of transient characteristics of an air source heat pump with vapor injection during reverse-cycle defrosting”, *Applied Energy*, DOI: 10.1016/j.ijrefrig.2017.12.017, vol. 88, pp. 24-34, April 2018.

Contacts: Hongtao Qiao

Literature review indicates that there is a dearth of modeling studies on the defrosting dynamics of air source heat pumps (ASHPs) due to the complex underlying physics and numerous computation details. In an effort to bridge the research gap, we present a five-stage hot-gas defrost model which is incorporated into a distributed-parameter heat exchange model integrated with a detailed frost growth model proposed in Qiao et al. (2017). Numerical treatments are then proposed to smooth the discontinuous transition between different defrosting stages, resulting in a significant improvement in numerical robustness. The developed models and the component models described in Qiao et al. (2015a) are applied to construct the system model of an air source flash tank vapor injection (FTVI) heat pump. Dynamic simulation is used to explore the transient fluid flow and heat transfer phenomena of the system during reverse-cycle defrosting (RCD).

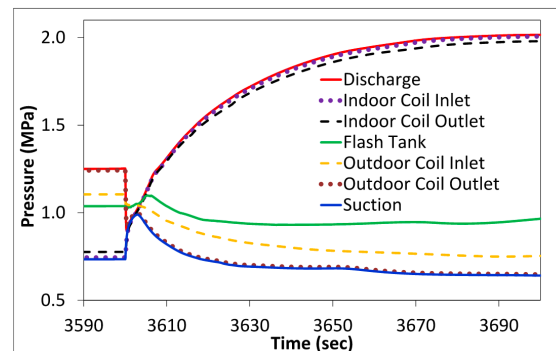

Modeling and Coordinated Control of an Air-Source Heat Pump and Hydronic Radiant Heating System

Citation: Laughman, C.R.; Bortoff, S.A.; Qiao, H., "Modeling and Coordinated Control of an Air-Source Heat Pump and Hydronic Radiant Heating System", *Japanese Modelica Conference*, May 2018.

Contacts: Christopher R. Laughman, Scott A. Bortoff, Hongtao Qiao

Hydronic radiant heating systems embedded in building constructions are receiving increased interest due to their potential for high energy efficiency and improved thermal comfort, but their slow time constants pose challenges when controlling space conditions. We address this problem via a system architecture that combines the radiant heating system with a separate air-source heat pump serving the same space. In this paper, we develop a new coordinating control method for this proposed system by using a set of reduced order models generated from a set of coupled Modelica models of the individual subsystems. This new control architecture does not require significant modification of standard heat pump control architectures, and results in both improved thermal comfort and reduced energy consumption.

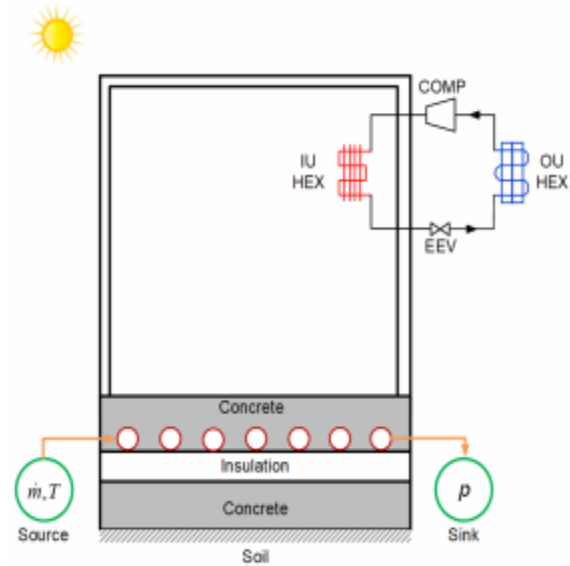

Metamaterial Absorber for THz Polarimetric Sensing

Citation: Wang, B., Sadeqi, A., Ma, R., Wang, P., Tsujita, W., Sadamoto, K., Sawa, Y., Rezaei Nejad, H., Sonkusale, S., Wang, C., Kim, M., Han, R., "Metamaterial Absorber for THz Polarimetric Sensing", *SPIE Photonics West*, DOI: 10.1117/12.2293122, February 2018.

Contacts: Bingnan Wang, Rui Ma, Pu (Perry) Wang

THz encoders have distinct advantages for position sensing compared with other types of encoders, such as those based on optical and inductive sensors. A polarization-dependent metamaterial absorber reflects one polarization while absorbs the other, which makes it an ideal building block for the barcode of a THz encoder system. In this paper, we present the design, fabrication, and experiments of a THz polarization-dependent metamaterial absorber, and its application to a polarimetric sensing system.

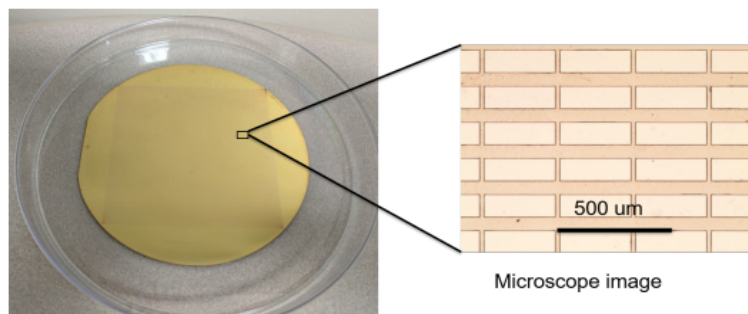

A coherent description of thermal radiative devices and its application on the near-field negative electroluminescent cooling

Citation: Lin, C., Wang, B., Teo, K.H., Zhang, Z., "A coherent description of thermal radiative devices and its application on the near-field negative electroluminescent cooling", *Energy - Journal*, DOI: 10.1016/j.energy.2018.01.005, January 2018
 Contacts: Chungwei Lin, Bingnan Wang, Koon Hoo Teo, Ziming Zhang

Using the transmissivity between two thermal reservoirs and the generalized Planck distributions, we describe devices that use radiative energy transfer between thermal reservoirs in a unified formalism. Four types of devices are distinguished. For power generators that use the temperature difference between reservoirs, photovoltaic (PV) and thermos-radiative (TR) devices respectively use the low-temperature photovoltaic cell and high-temperature thermos-radiative cell to generate electricity. For active cooling, the electroluminescent (EL) cooling devices apply a forward bias voltage on the object we want to cool, whereas the negative EL cooling devices apply a reverse-bias voltage to the heat sink. The relationship among these four devices is explicated. The performance of the negative EL cooling is analyzed, both in the Shockley-Queisser (blackbody spectrum and radiative recombination) framework and near-field enhancement. One advantageous feature of the negative EL cooling is that it does not apply the voltage to the target object which we want to cool, and the nearfield enhancement can apply to various target materials that support surface resonant modes.

(b) $T_c = 300K, T_s = 300K$

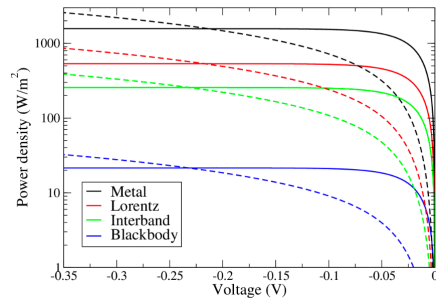

Beyond Thermal Management: Incorporating p-Diamond Back-barriers and Cap-layers into AlGaIn/GaN HEMTs

Citation: Zhang, Y.; Teo, K.A.; Tomas, P., "Beyond Thermal Management: Incorporating p-Diamond Back-barriers and Cap-layers into AlGaIn/GaN HEMTs", *IEEE Transaction on Electron Devices*, DOI: 10.1109/TED.2016.2553136, April 2016.
 Contacts: Koon Hoo Teo

This work explores the use of p-diamond back-barriers and cap-layers to enhance the performance of GaN-based high electron mobility transistors (HEMTs). Diamond can offer a heavily-doped p-type layer, which is complementary to GaN electronics. Self-consistent electro-thermal simulations reveal that the use of p-diamond back-barriers and cap-layers can increase the breakdown voltage of GaN-based HEMTs by four-fold, at the same time that they enhance the 2DEG confinement and reduce short channel effects.

